

## Submittal Data

# GAHP Line W LB Series

## Ground Source Gas Fired Absorption Heat Pump

### Heating and Cooling

GAHP is the acronym for Gas Absorption Heat Pump. The GAHP-W is a high efficiency water-cooled heat pump, utilizing a water-ammonia absorption cycle that is designed for indoor use. The GAHP-W LB is designed to recover thermal energy from the ground through a buried geothermal loop: it is used to heat rooms and produce hot

water for domestic purposes. The unit is able to heat water up to 140 °F and chill water down to 23 °F with a heating efficiency up to 125%. The cycle of the GAHP-W LB is driven by thermal energy provided by a gas burner. Therefore, the required electric energy is limited to feed the electronic control system and the pump motor. The GAHP-W LB is fed by

natural gas or LPG, and supplied with 208-230 V - 60 Hz SINGLE PHASE electrical power. The evacuation of combustion products takes place through an appropriate exhaust terminal, located on the side of the appliance, with outlet in a vertical position.



#### Operating mode

Three different consent management mode options may be selected from the unit's S60 electronic control board or the Optional Direct Digital Controller, with the control of the inlet or outlet water temperature. The three options are used to make the unit manage a specific operating request, through the assignment of a priority, which can be:

- HOT PRIORITY (satisfies the heating request);
- COLD PRIORITY (satisfies the chilling request);
- NO PRIORITY (satisfies the heating/chilling request).

This last option can only be programmed from the S60

electronic control board and only be used by the stand-alone board (no DDC installed).

The GAHP-W LB is equipped with the following devices:

- mild steel sealed circuit, externally coated with epoxy paint;
- pre-mixed multigas burner, multiple gas type with ignition and flame sensing device managed by an electronic control box;
- evaporator for chilled water: tube in shell type, made of titanium stainless steel, externally insulated with polystyrene;
- condenser/absorber for

heated water: tube in shell type, made of titanium, externally insulated with polystyrene.

#### Control and safety devices

The GAHP-W LB is controlled and monitored by the S60 control board through the peripheral W10 card.

These cards and other components compose the control and safeties of the GAHP-W LB, as listed below:

- S60 Electronic Control Board with integrated microprocessor, LCD display and encoder located inside the electric box; it is programmable and it controls and monitors the

- operation of the heat pump;
- water flow switches; located on the return chilled water lines; monitor both the hot and cold water flow and help prevent the freezing of the evaporator and the overheating of the condenser-absorber;
- sealed circuit high temperature limit; located on the external wall of the generator; helps prevents overheating of the generator;
- hot water high temperature limit switch; located on the outlet water line; prevent water circuit from overheating;
- differential air pressure switch; located inside the

<p>electric box; it helps manage the combustion system by monitoring the air flowing into the air-gas mixing chamber and stopping the burner if the air flow is too low;</p> <ul style="list-style-type: none"> <li>flue gas temperature limit switch; located inside the rear portion of the combustion chamber; helps</li> </ul>	<p>prevent overheating of the generator;</p> <ul style="list-style-type: none"> <li>sealed circuit safety relief valve;</li> <li>safety by-pass valve; located inside the sealed system; prevents over pressurizing of the sealed system;</li> <li>antifreeze function for hydronic system; together</li> </ul>	<p>with the flow switches, this electronic function programmed into the microprocessor, helps prevent the freezing of the two water heat exchangers;</p> <ul style="list-style-type: none"> <li>ignition control box; located inside the electric box; it manages the combustion system controlling the burner ignition, the gas</li> </ul>	<p>valve, the air pressure switch, the air blower and the flame sensor;</p> <ul style="list-style-type: none"> <li>dual gas valve;</li> <li>temperature probes; located both on the sealed system and on the water lines; they monitor functional parameters of the unit.</li> </ul>
--	---	---	--

**PERFORMANCE RATINGS - HEATING <sup>(1)</sup>**

**GAHP-W-LB**

Heating capacity <sup>(2)</sup>		BTU/h	119,400
Gas input		BTU/h	95,500
Ambient operating temperature	maximum	°F	113
	minimum	°F	10.4
Hot water temperature	maximum outlet (to hydronic system)	°F	140
	maximum inlet (to unit)	°F	113
Water flow	nominal	GPM	13.2
Internal pressure drop at nominal water flow		Feet of Head	10.5
		psi <sub>g</sub>	4.5

**PERFORMANCE RATINGS - COOLING <sup>(1)</sup>**

Cooling capacity <sup>(2)</sup>		BTU/h	46,100
Gas input		BTU/h	95,500
Chiller water temperature	minimum outlet (to hydronic system)	°F	23
	maximum inlet (to unit)	°F	113
Chilled water flow	nominal	GPM	11
Internal pressure drop at nominal water flow		Feet of Head	15.4
		psi <sub>g</sub>	6.67

**ELECTRICAL RATINGS <sup>(1)</sup>**

Required voltage, 60 Hz, single phase <sup>(3)</sup>	V	208-230
Operating consumption, chiller + heater <sup>(4)</sup>	kW	0.4
MCA (Minimum Circuit Ampacity)	A	4.5
MOP (Maximum Overcurrent Protection)	A	8.1

**PHYSICAL DATA <sup>(1)</sup>**

Operating weight	pounds	630	
Dimensions	width	inches	33 1/2
	length	inches	25 3/4
	height	inches	50 3/4

<sup>(1)</sup> All illustrations and specifications contained herein are based on the latest information available at the time of publication.

<sup>(2)</sup> GAHP-W LB standard test conditions: B32/W122.

<sup>(3)</sup> Units are factory-wired for 208-230 volts operation.

<sup>(4)</sup> May vary by ± 10% as function of both power supply and electrical motor input tolerance.

**Due to continuous product innovation and development, Robur reserves the right to change product specifications without prior notice.**

**HEATING MODE CAPACITY (BTU/h)**

Chilled water inlet temperature	Hot water inlet temperature					
	77.0 °F	86.0 °F	95.0 °F	104.0 °F	113.0 °F	113.0 °F
	$\Delta T = 18\text{ °F}$					$\Delta T = 27\text{ °F}$
32.0 °F	132,700	129,700	125,200	119,400	112,000	112,000
41.0 °F	133,700	131,700	129,000	124,600	117,500	117,500
50.0 °F	133,800	133,100	131,300	128,400	122,800	122,800
59.0 °F	133,800	133,700	132,600	131,000	127,400	127,400
68.0 °F	133,800	133,800	133,200	132,400	130,700	130,700
77.0 °F	133,800	133,800	133,500	132,900	132,500	132,500

$\Delta T$  is the difference between outlet and inlet temperature.

**COOLING MODE CAPACITY (BTU/h)**

Chilled water inlet temperature	Hot water inlet temperature					
	77.0 °F	86.0 °F	95.0 °F	104.0 °F	113.0 °F	113.0 °F
	$\Delta T = 18\text{ °F}$					$\Delta T = 27\text{ °F}$
32.0 °F	55,900	53,900	50,500	46,100	37,600	37,600
41.0 °F	57,400	56,000	53,500	49,800	43,100	43,100
50.0 °F	58,200	57,300	55,800	53,300	48,000	48,000
59.0 °F	58,400	58,000	57,100	55,600	52,000	52,000
68.0 °F	58,400	58,100	57,500	56,600	54,800	54,800
77.0 °F	58,400	58,100	57,500	56,700	56,000	56,000

$\Delta T$  is the difference between outlet and inlet temperature.

**PRESSURE DROP - Heating mode**

Hot water flow	Outlet water temperature		
	86.0 °F	104.0 °F	122.0 °F
GPM	$\Delta P$ (Feet of Head)		
6.60	3.29	3.14	2.91
7.71	4.17	3.98	3.71
8.81	5.28	5.02	4.70
9.91	6.60	6.25	5.89
11.01	8.12	7.67	7.25
12.11	9.83	9.25	8.79
13.21	11.72	11.00	10.47
14.31	13.77	12.90	12.31
15.41	15.97	14.94	14.27
16.51	18.30	17.11	16.36
17.61	20.76	19.41	18.56
18.71	23.32	21.81	20.86
19.81	25.98	24.32	23.25
20.91	28.73	26.92	25.71
22.01	31.55	29.60	28.24

**PRESSURE DROP - Cooling mode**

Hot water flow	Outlet water temperature		
	23.0 °F	32.0 °F	41.0 °F
GPM	$\Delta P$ (Feet of Head)		
6.60	6.36	5.36	4.66
7.71	8.37	7.03	6.12
8.81	10.72	9.04	7.87
9.91	12.73	11.05	9.61
11.01	15.40	13.40	11.65
12.11	17.75	15.74	13.69
13.21	20.43	18.42	16.02
14.31	23.11	20.76	18.06
15.41	26.12	23.44	20.39
16.51	29.13	26.12	22.73
17.61	32.15	28.80	25.06

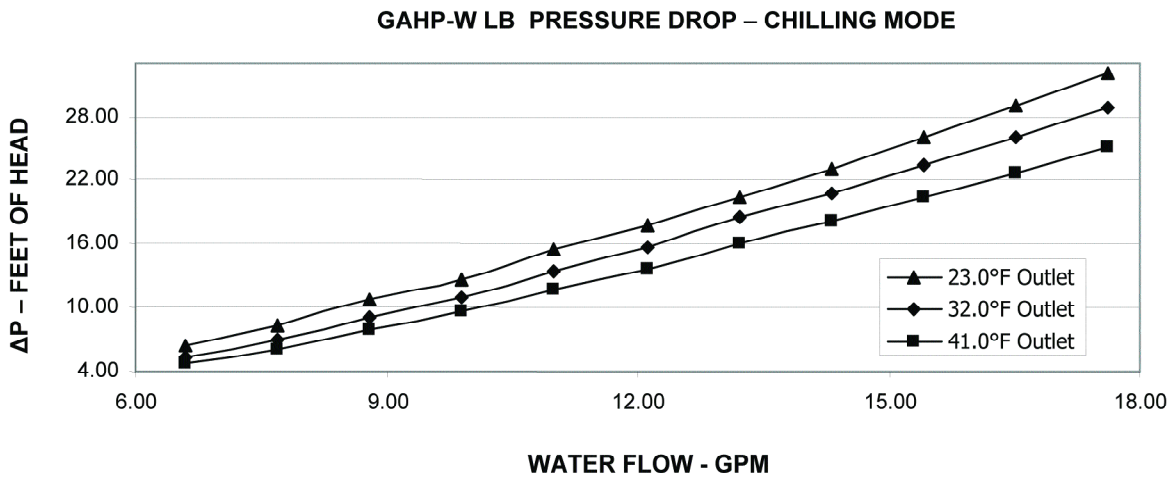
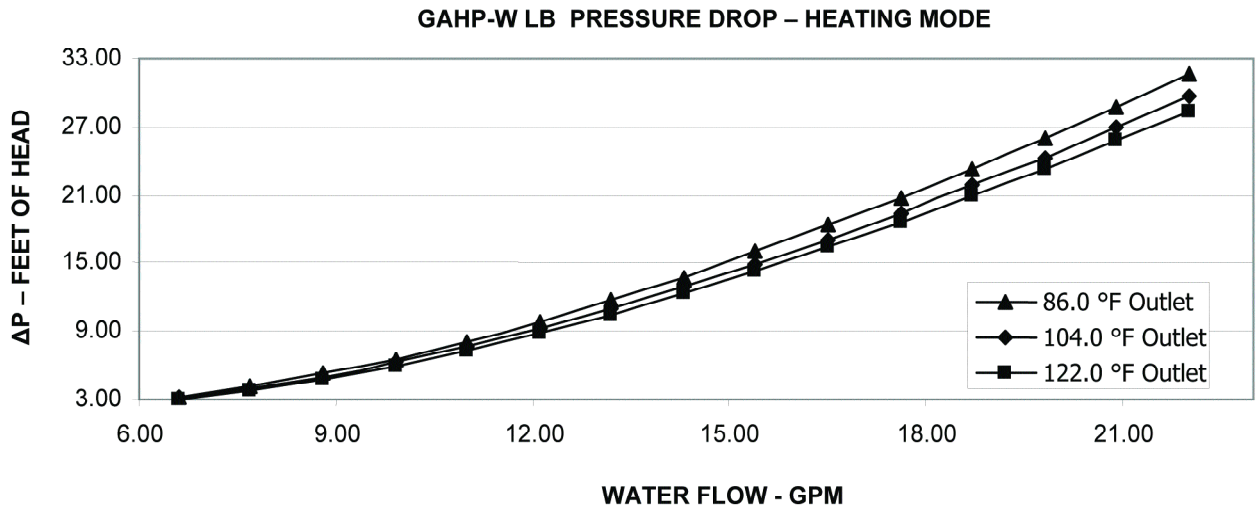

**APPROXIMATE WATER FREEZING POINT TEMPERATURE**

Percentage of monoethylene glycol	10	15	20	25	30	35	40
Water freezing point temperature (°F)	26.6	23.0	17.6	10.4	5.0	-4.0	-13.0
Percentage of increase in pressure drop	--	6	8	10	12	14	16
Loss of efficiency of unit	--	0.5	1	2	2.5	3	4

The numbers provided in this table are approximate and you must refer to the glycol manufacturer's instructions for additional instructions and amount of glycol required based on expected ambient conditions.

**GAHP-W LB DIMENSIONS**

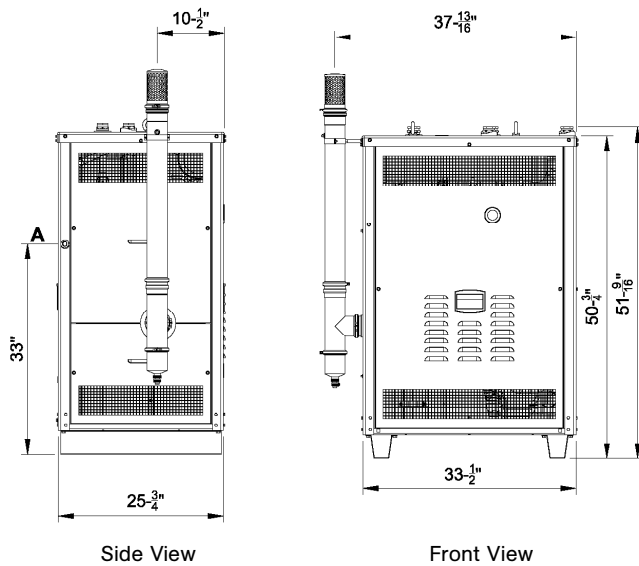

**GAHP-W LB SERVICE PLATE DIMENSIONS**

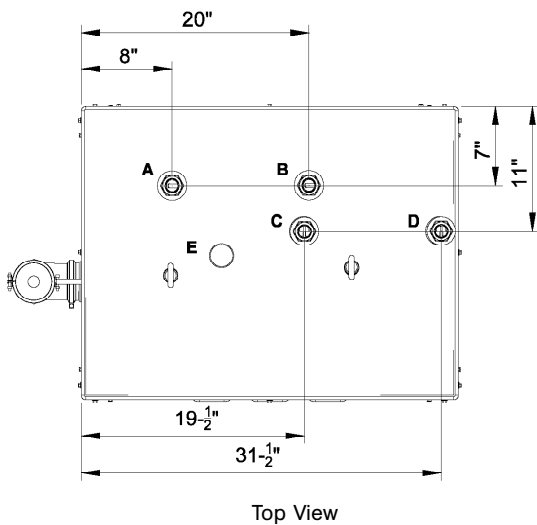

- A Chilled water inlet ø 1" FPT
- B Hot water inlet ø 1" FPT
- C Chilled water outlet ø 1" FPT
- D Hot water outlet ø 1" FPT
- E Discharge valve canalization plug

**GAHP-W LB HYDRONIC SYSTEM: Typical Installation Arrangement (External Components not included with Robur Unit)**

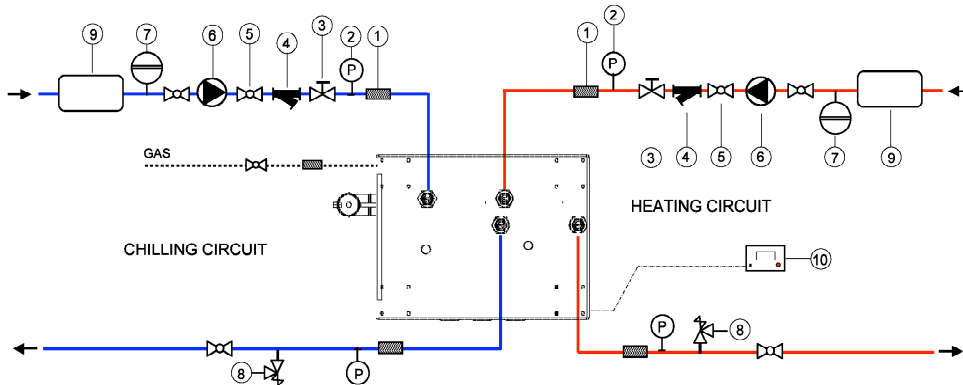

- |                                |                              |
|--------------------------------|------------------------------|
| 1 Antivibration flexible hoses | 6 Circulating water pump     |
| 2 Pressure gauge               | 7 Expansion tank             |
| 3 Flow regulating valve        | 8 Safety valve               |
| 4 Water filter                 | 9 Water storage              |
| 5 Shut-off valve               | 10 DDC (optional from Robur) |

**Clearances**

Position the appliance so that minimum clearances from combustible surfaces and constructions (walls and

other equipment) are maintained, as shown in the figure below. The appliance may be installed directly on wood

flooring. Minimum clearances are necessary for operating performance, and in order to be able to carry out

maintenance operations.

**Observe all local and State codes.**

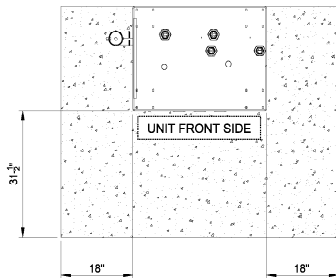

Single unit

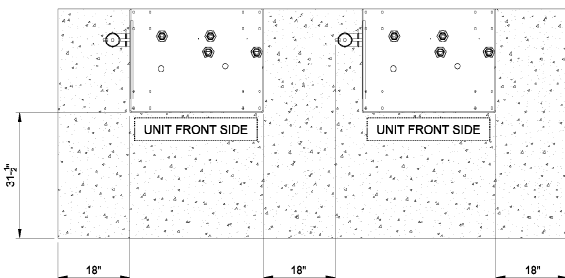

Multiple units