



## Absorption Chillers

RTCF120-00 HT	10 Ton Chiller-Links
RTCF180-00 HT	15 Ton Chiller-Links
RTCF240-00 HT	20 Ton Chiller-Links
RTCF300-00 HT	25 Ton Chiller-Links



CHILLER-LINKS

### Brief description

ROBUR's high efficiency chiller-links are comprised of multiple combinations of ACF60-00 HT chiller modules, which utilize an ammonia/water absorption cycle that is air-cooled and designed for outdoor installation. Their primary energy source is natural or propane gas resulting in minimal, single-phase electrical service requirements.

With no engines or mechanical compressors and only three moving parts in each sealed refrigeration cycle, ROBUR RTCF HT chiller-links are a reliable and durable source of chilled water. These environmentally friendly, commercial grade appliances are able to chill water even in hot climate areas, with external ambient temperature up to 131 °F (55.0 °C).

The RTCF HT chiller-links offer complete flexibility for light commercial and residential comfort air conditioning and industrial technological applications.

### Features

The RTCF HT links are composed by a minimum of 2 up to a maximum of 5 units.

The units are already assembled and connected hydraulically and electrically on a single base made of steel beams, so as to comprise a single chilling unit complete with hydraulic manifolds and general electric panel.

The two hydraulic manifolds, located under the units, extend over the entire length of the base: the connectors for the piping of the hydraulic plant are located on the right side of the appliance, but may also be located on the left side.

Each single unit that forms part of the appliance has advanced technical manufacturing characteristics, control and safety components; below the main ones:

- cooling circuit in steel, treated on the outside with epoxy paint;
- multigas pre-mixing burner equipped with ignition and flame detection device, managed by an electronic control unit;
- air-based heat exchanger with single position finned coil manufactured in steel tubing and aluminum fins;
- water based exchanger of the shell-and-tube type in titanium alloyed stainless steel, externally insulated;
- variable-flow microprocessor-controlled helicoidal motor-fan (summer operation).
- S61 electronic control board with microprocessor, Direct Digital Controller (DDC) with LCD display and encoder.
- Pressure safety valve and many other control and safety devices.

**Technical data**

RTCF HT TECHNICAL CHARACTERISTICS <sup>(1)</sup>						
GENERAL TECHNICAL DATA		UNITS	RTCF HT 120-00	RTCF HT 180-00	RTCF HT 240-00	RTCF HT 300-00
<b>OPERATING DATA</b>						
GAS INPUT (HHV)	NOMINAL	kBtu/hr (kW)	189.8 (55.6)	284.7 (83.4)	379.6 (111.2)	474.5 (139.0)
COOLING CAPACITIES <sup>(2)</sup>		kBtu/hr (kW)	116.8 (34.22)	175.2 (51.36)	233.6 (68.48)	292.0 (85.60)
CHILLED WATER FLOW RATE	NOMINAL		23.6 (5,350)	35.4 (8,025)	47.2 (10,700)	59.0 (13,375)
	MINIMUM	GPM (l/hr)	22.0 (5,000)	33.0 (7,500)	44.0 (10,000)	55.0 (12,500)
	MAXIMUM		28.2 (6,400)	42.3 (9,600)	56.4 (12,800)	70.5 (16,000)
SOUND RATING <sup>(3)</sup>		dB(A)	50/58	52/60	53/61	54/62
AMBIENT OPERATING TEMPERATURE	MINIMUM MAXIMUM	°F (°C)	32.0 (0) 131.0 (55.0)			
INLET (TO THE UNITS) WATER TEMPERATURE	MAXIMUM	°F (°C)	113.0 (45)			
OUTLET (TO THE PLANT) WATER TEMPERATURE	MINIMUM	°F (°C)	41.0 (5)			
<b>ELECTRICAL DATA</b>						
REQUIRED VOLTAGE (60 Hz, single phase)		V	208 - 230			
MINIMUM CIRCUIT AMPACITY (MCA) Unit only		A	16.0	24.0	32.0	40.0
MAXIMUM OVER CURRENT PROTECTION (MOCP)		A	21.8	32.7	43.6	54.5
ELECTRICAL OPERATING COMPSUMPTION PER SINGLE CHILLER MODULE <sup>(4)</sup>		kW	0.75			
<b>HYDRAULIC CONNECTIONS</b>						
WATER CONNECTION DIAMETERS (OUTLET / INLET)		FPT	1- <sup>1</sup> / <sub>2</sub> "		2"	
GAS INLET CONNECTION DIAMETER		FPT	1"		1- <sup>1</sup> / <sub>4</sub> "	
INTERNAL PRESSURE DROP		In <sub>wc</sub> (bar <sub>g</sub> )	9.7 (0.29)			
MAXIMUM OPERATING PRESSURE		PSI <sub>g</sub> (bar <sub>g</sub> )	43.5 (3.0)			
<b>PHYSICAL DATA</b>						
WATER CONTENT OF APPLIANCE <sup>(5)</sup>		gal (l)	4.25 (16.0)	6.25 (23.6)	10.0 (37.8)	12.5 (47.3)
OPERATING WEIGHT		lb (kg)	2,078 (942)	3,117 (1,414)	4,156 (1,885)	5,195 (2,356)
DIMENSIONS	WIDTH		93.00 (2,360)	144.00 (3,657)	195.00 (4,950)	246.00 (6,250)
	DEPTH	Inches (mm)	48.50 (1,230)	48.50 (1,230)	48.50 (1,230)	48.50 (1,230)
	HEIGHT		53.25 (1,390)	53.25 (1,390)	53.25 (1,390)	53.25 (1,390)

**Table 1** - RTCF HT Technical characteristics.

**Notes to Table 1:**

1. All illustrations and specifications contained herein are based on the latest information available at the time of publication approval. Robur reserves the right to make changes at any time without notice, in materials, specifications, and models or to discontinue models.
2. Capacity at standard conditions of 95 °F ambient temperature. Chilled water Outlet temperature 45°F, chilled water Inlet temperature 55 °F. Capacity characteristics are shown in the table below. Interpolations between tabled values

are permissible, but do not extrapolate. For capacities at ambient temperatures higher than in table, contact Robur Corp., see address on the back cover.

3. Recorded 16 feet from unit in open space. When the ambient temperature is less than 91°F, there is a reduction in condenser fan speed.
4. May vary by ±10% as a function of both power supply and electrical motor input tolerance. Consumption does not include water circulating pump and air handler(s).
5. "Chilled Water" refers to a solution of quality tap water and 20% by volume of inhibited permanent antifreeze. Higher antifreeze concentrations may be required to protect water circuit to lowest expected ambient conditions for the installation area.

**RTCF HT cooling capacities correction factors**

AMBIENT AIR TEMPERATURE °F (°C)	OUTLET CHILLED WATER °F (°C)				
	41.0 (5.0)	44.6 (7.0)	50.0 (10.0)	54.5 (12.5)	57.2 (14.0)
32.0 (0)	1.02	1.02	1.02	1.02	1.03
35.6 (2.0)	1.02	1.02	1.02	1.02	1.03
39.2 (4.0)	1.02	1.02	1.02	1.02	1.03
42.8 (6.0)	1.02	1.02	1.02	1.02	1.03
46.4 (8.0)	1.02	1.02	1.02	1.02	1.03
50.0 (10.0)	1.02	1.02	1.02	1.02	1.03
53.6 (12.0)	1.02	1.02	1.02	1.02	1.03
57.2 (14.0)	1.02	1.02	1.02	1.02	1.03
60.8 (16.0)	1.02	1.02	1.02	1.02	1.03
64.4 (18.0)	1.02	1.02	1.02	1.02	1.03
68.0 (20.0)	1.02	1.02	1.02	1.02	1.03
71.6 (22.0)	1.02	1.02	1.02	1.02	1.03
75.2 (24.0)	1.02	1.02	1.02	1.02	1.03
78.8 (26.0)	1.01	1.02	1.02	1.02	1.03
82.4 (28.0)	1.01	1.02	1.02	1.02	1.03
86.0 (30.0)	1.01	1.02	1.02	1.02	1.03
89.6 (32.0)	0.99	1.02	1.02	1.02	1.03
93.2 (34.0)	0.96	1.01	1.01	1.01	1.02
95.0 (35.0)	0.94	1.00	1.00	1.01	1.02
96.8 (36.0)	0.92	0.99	1.00	1.00	1.02
100.4 (38.0)	0.87	0.97	0.99	0.99	1.01
104.0 (40.0)	0.82	0.93	0.97	0.98	1.00
107.6 (42.0)	-	0.88	0.94	0.97	0.99
111.2 (44.0)	-	0.82	0.91	0.95	0.97
114.8 (46.0)	-	-	0.86	0.92	0.95
118.4 (48.0)	-	-	0.80	0.87	0.91
131.0 (55.0)	-	-	-	0.81	0.86

**Table 2** - Multiplicative cooling power correction factors for external ambient air and outlet chilled water temperatures that differ from nominal ones.

**Dimensions and clearances**

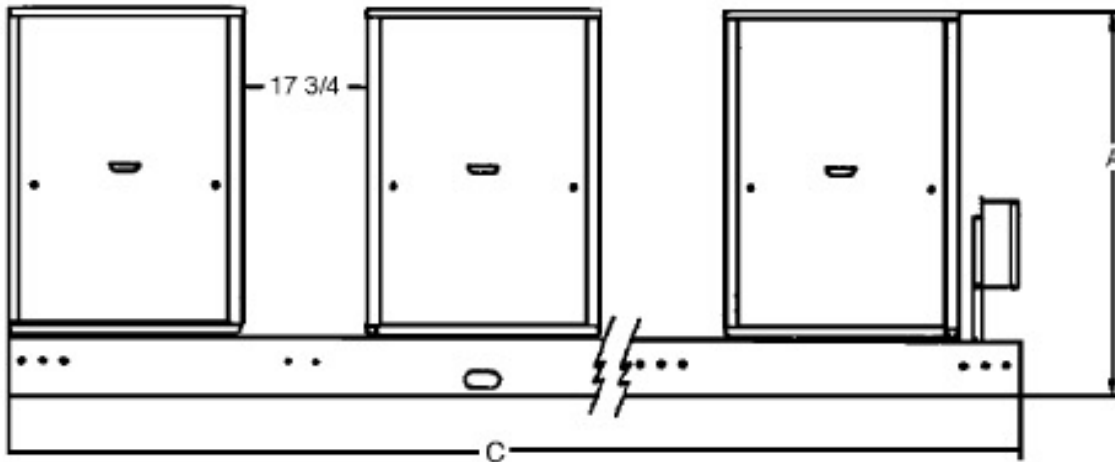

**FRONT VIEW**

MODEL	A	B Depth (Not Shown)	C
RTCF120	53.25	48.50	93.0
RTCF180	53.25	48.50	144.0
RTCF240	55.25	48.50	195.0
RTCF300	55.25	48.50	246.0

**RIGHT END VIEW**

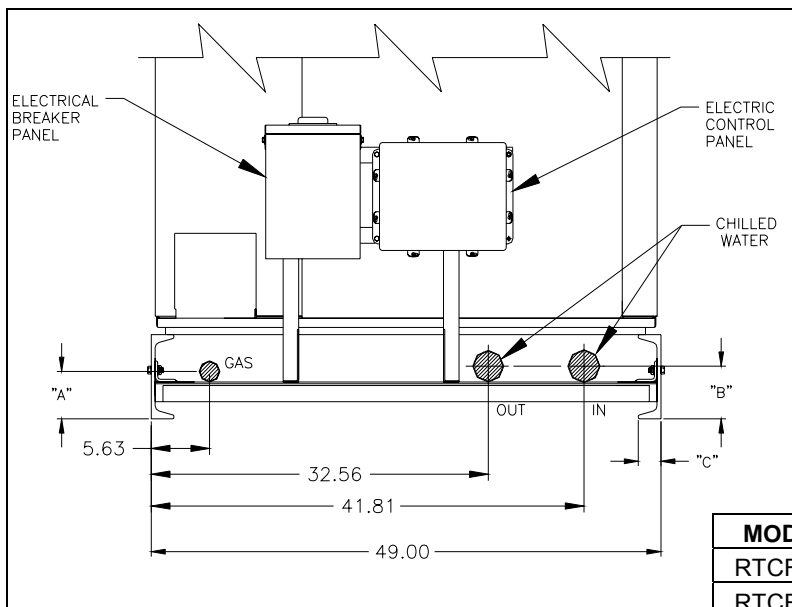

MODEL	A	B	C
RTCF120	3 1/8	3 5/8	1 7/8
RTCF180	3 1/8	3 5/8	1 7/8
RTCF240	5 3/8	6.0	2 3/8
RTCF300	5 3/8	6.0	2 3/8

**Figure 1** - RTCF HT external dimensions and piping specifications; dimensions in inches.

### Lifting and positioning the appliance on site

The appliance must be kept in the same packing in which it left the factory while it is moved on the site; packing must only be removed upon final installation.

If the appliance has to be lifted, connect two cables to the holes provided on the base and use suspension and spacer bars to prevent the cables of the hoist from damaging the panels while the appliance is moved.



The hoist and all accessory equipment (braces, cables, bars) must be of adequate dimensions in relation to the load to be lifted. For the weight of the appliance, refer to Table 1 on page 2.

**The manufacturer cannot be held responsible for any damage that occurs during the setting up of the appliance.**

The appliance can be installed at ground level, or on a terrace or roof if they are able to sustain its dimensions and weight.



The dimensions of the appliance are given in Table 1 on page 2.

## SUPPORTING BASE

Always position the appliance on a flat level surface that is made of fireproof material and able to sustain the weight of the appliance itself.

In addition, provide a small containing step to prevent water from spilling over during winter defrosting operations.

### Installation at ground level

If a horizontal base is not available (see also "SUPPORTS AND LEVELLING" - page 6), it is necessary to create a flat level base in concrete that is at least 4÷6" (100-150 mm) larger than the dimensions of the base of the appliance on each side.

The dimensions of the appliance are given in Table 1 on page 2.

Provide a small containing step and suitable drainage channel for the water.

### Installation on terrace or roof

Position the appliance on a flat level surface that is made of fireproof material (see also "SUPPORTS AND LEVELLING" - page 6).

The structure of the building must be able to sustain the weight of the appliance added to that of the supporting base.

The weight of the appliance is given in Table 1 on page 2.

Although the appliance produces only moderate vibrations, the use of anti-vibration supports (available as accessories) is especially recommended in cases in which the appliance is installed on a roof or terrace and therefore resonance phenomena may occur.

In addition, it is advisable to use flexible connections (anti-vibration joints) between the appliance and the hydraulic and gas supply pipes.



Avoid positioning the appliance directly above rest areas or other areas that require quiet.

## SUPPORTS AND LEVELLING

The appliance must be correctly leveled by placing a level on the upper part of the appliance.

If necessary, level the appliance with metal spacers, placing them appropriately in relation to the mounts. Do not use wooden spacers as these degrade quickly.

## CLEARANCES

Position the appliance so as to maintain **minimum clearances** from combustible surfaces, walls or other appliances, as illustrated in Figure 2 on the next page.



Minimum clearances are necessary in order to be able to carry out maintenance operations and to be able to guarantee the correct flow of air required for heat exchange with the finned coil.

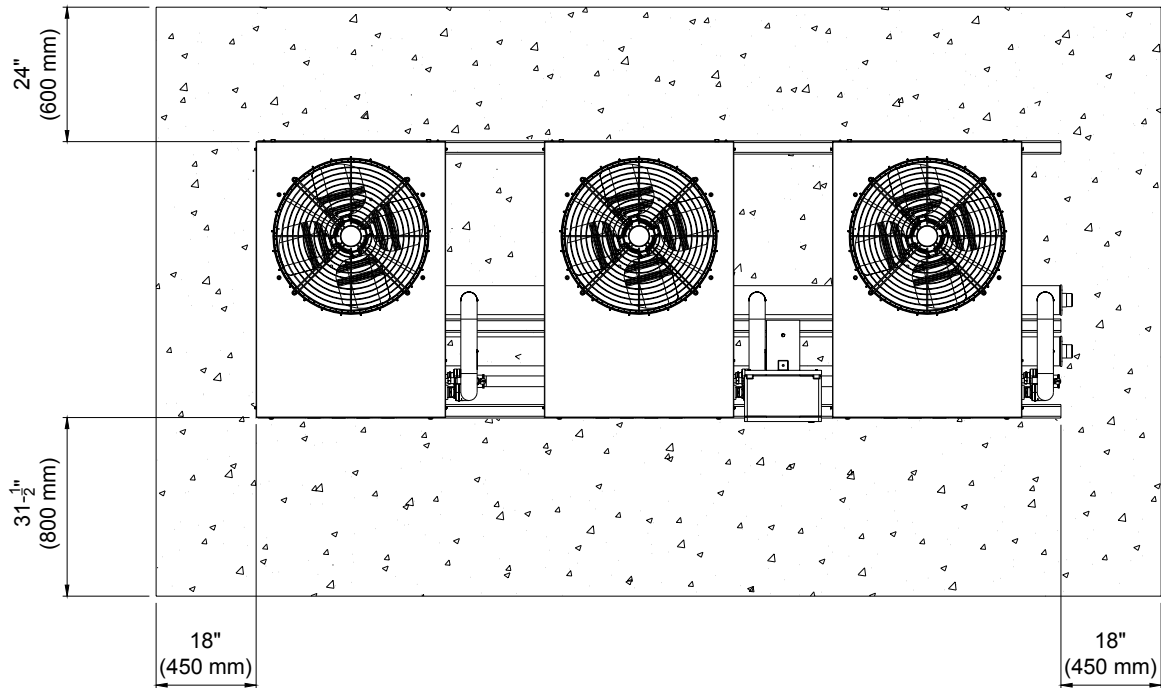

**Figure 2** - Minimum clearances from obstacles, walls and combustible surfaces.

Position the appliance preferably out of range of rooms and/or environments where strict silence is required, such as bedrooms, meeting rooms, etc.

Evaluate the noise impact of the appliance in consideration of the installation site: avoid installing the appliance in positions (corners of buildings, etc.) that could amplify the noise (reverb effect).

**Hydraulic and application information**

The RTCF HT Chiller-Link Series includes closed evaporators in each five ton chiller module. The water loop will be pressurized and require an expansion tank and an air bleed installed at the highest point in the water loop. A concentration of permanent inhibited antifreeze/glycol must be added to the water loop to prevent freezing in your particular region. A minimum 20% concentration is required in all regions. Operating the unit with no antifreeze will result in freezing the water in the units' evaporator during mild weather or light cooling load conditions. This freezing condition will result in improper water flow through the unit and may ultimately damage the units' evaporators.

Chiller-Links do not include a chilled water-circulating pump. A pump must be sized and obtained locally for your particular application. Remember, when sizing the pump, each five ton Chiller module has a nominal flow rate of 11.8 GPM (2675 l/hr); the internal pressure drop of the appliance is 9.7 InWC (ft. of head). This flow rate must be provided to each five ton chiller in the multiple unit configuration.

Example: Model RTCF300-00Five ACF60-00 manifolded into a 25 ton system.

Total flow rate = 59 GPM (5 units X 11.8 GPM)

Also account for the additional pressure drop of the water piping, fittings, antifreeze concentration and coil(s) in the water loop when sizing the pump.

The installer must ensure that the water pump and the chiller-Link unit start at the same time. Also, the pump must continue to run during the units' cycle down time (600 seconds after the opening of the control switch). Contacts in the chiller-link's control box may be used for this purpose if the pump's amp draw does not exceed 4 amps. See RTCF Manual for additional information.

Also, as indicated above, the water loop must contain a properly sized expansion tank and an air bleed must be installed at the highest point of the loop. In addition, water piping must include necessary fittings to properly fill the loop with a water/antifreeze mixture. Typical piping arrangement shown below:

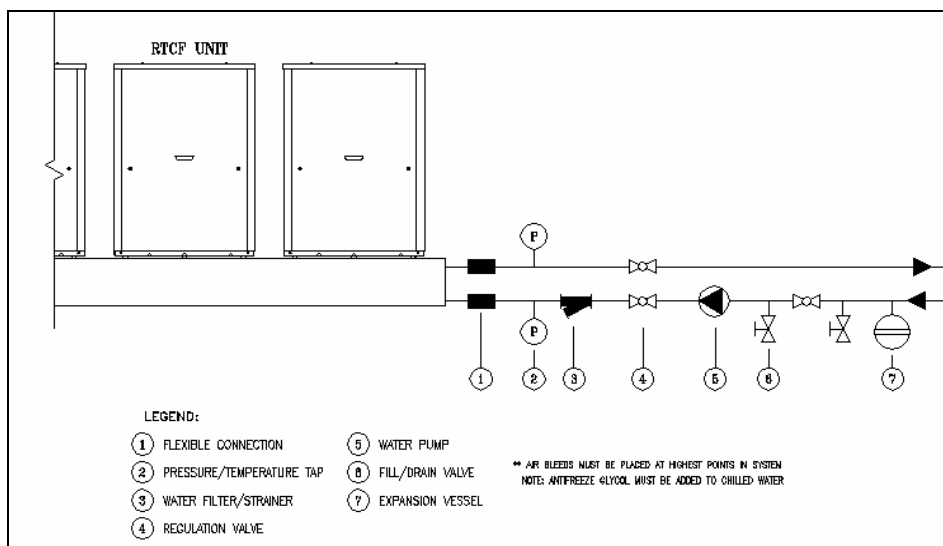

**Figure 3** - Typical piping arrangement.

**ROBUR Corporation** • 827 E Franklin Street • Evansville, IN 47711  
812-424-1800 • Fax: 812-422-5117