

Installation, use and maintenance manual

GA Line ACF 60-00 Model

Gas fired absorption chiller
for cooling medium-large areas

Natural gas/LPG fired



INDEX

| | |
|--|-----------|
| 1. GENERAL WARNINGS | 3 |
| 2. OVERVIEW AND TECHNICAL DATA | 5 |
| 2.1 OVERVIEW | 5 |
| 2.2 GAS FIRED CHILLER OPERATION CYCLE | 6 |
| 2.3 TECHNICAL DATA: ACF60-00 (STANDARD, HR, HT, TK, LB VERSIONS) | 8 |
| STANDARD VERSION | 8 |
| HT VERSION | 10 |
| TK VERSION | 13 |
| ACF60-00 UNIT INTERNAL PRESSURE DROP (Standard, HT, TK versions) ... | 15 |
| LB VERSIONS | 16 |
| ACF60-00 LB UNIT INTERNAL PRESSURE DROP | 20 |
| HR VERSION | 21 |
| ACF60-00 HR UNIT INTERNAL PRESSURE DROP OPERATION FOR AIR CONDITIONING ONLY (NO RECOVERY) | 26 |
| ACF60-00 HR HEAT RECOVERY UNIT INTERNAL PRESSURE DROP | 26 |
| 2.4 DIMENSIONS | 27 |
| 3. INSTALLATION | 28 |
| 3.1 GENERAL RULES | 28 |
| 3.2 INSTALLATION OF THE UNIT | 29 |
| 4. HYDRONIC AND GAS INSTALLATION | 34 |
| 4.1 WATER PIPING DESIGN AND INSTALLATION | 34 |
| 4.2 GAS SUPPLY PIPING | 38 |
| 5. ELECTRICAL CONNECTION | 39 |
| 5.1 POWER SUPPLY AND PUMP WIRING FOR A SINGLE ACF60-00 UNIT | 39 |
| 5.2 POWER SUPPLY AND PUMP WIRING FOR 2 OR MORE ACF60-00 UNITS | 41 |
| 5.3 CONTROL SWITCH WIRING AND THERMOSTAT LOCATION | 42 |
| 5.4 ACF60-00 WIRING | 43 |
| 5.5 DDC CONNECTION | 44 |
| 6. START-UP AND ADJUSTMENT | 53 |
| 6.1 FILLING THE WATER PIPING | 53 |
| 6.2 GAS PRESSURE ADJUSTEMENT | 55 |
| 6.3 CHILLED WATER TEMPERATURE REGULATION | 57 |
| 7. SERVICING AND MAINTENANCE | 59 |
| 8. ADAPTING TO ANOTHER GAS | 61 |
| 9. SPARE PARTS | 63 |
| 10. APPENDIX | 71 |
| TABLE OF OPERATING CODES GENERATED BY ELECTRONIC BOARD (firmware version 3.002) | 75 |

NOTE

Carefully read the information contained in this manual. It contains important instructions regarding installation, use and maintenance safety. Save this manual for any future needs. The manufacturer cannot be held responsible for any damages from improper, erroneous or irrational use.

With the aim of continuously improving the quality of our products, manufacturer reserves the right to change reported instructions and drawings without any prior notice.

1. GENERAL WARNINGS

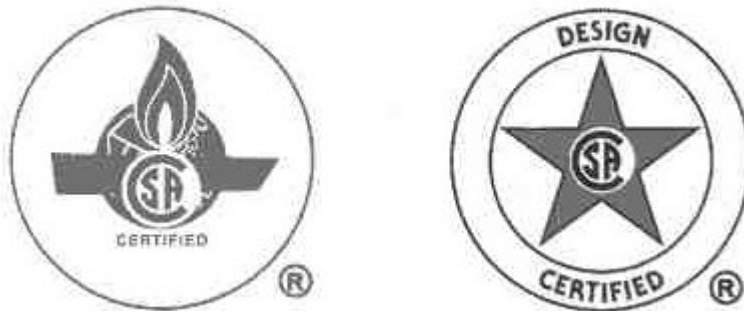

This manual is an integral and essential part of the product and must be given to the owner.

Only qualified technicians, strictly complying with the manufacturer's instructions and the local standards, should install this product. The manufacturer will not accept responsibility for personal injuries or property damage resulting from improper installation.

Qualified technicians are those having specific technical competence in air conditioning and gas appliances according to international and national standards.

This appliance must be used exclusively for its intended purpose. All chilling applications must be in accordance with the operating specifications of the unit. Any other use is considered improper and, therefore, dangerous. Steps must be taken to avoid improper use and potential dangers.

The fluids used in the sealed refrigerant circuit may cause health problems if inhaled, ingested or when allowed to come into contact with the skin. It is recommended that no work be performed on the sealed refrigerant circuit except by a qualified service technician or engineer. Care should also be taken not to disturb or handle the valves of the chiller's sealed refrigerant circuit.

The manufacturer will not accept contractual or non-contractual liability for damages resulting from improper installation or misuse of the unit or intentional disregard of any of the manufacturer's instructions.

After unpacking the unit, check the unit for integrity. Due to the potential danger, keep all packaging materials (plastic bags, polystyrene foam, nails, etc.) away from children.

Before installation, it is recommended that all chilled water and gas supply piping be flushed. If not flushed prior to installation, residual materials may be left in the piping that could cause improper functioning of the chiller.

The installation of the appliance must conform to the requirements of the authority having jurisdiction or in the absence of such requirements, to the latest edition of the **National Fuel Gas Code, ANSI Z223.1**. If the unit is installed in Canada, the installation must conform to the **Canadian Gas Association Standard CAN1 B149.1** and **.2**.

The chiller's electrical connections and grounding must be in accordance with the latest edition of the **National Electrical Codes, ANSI/NFPA No. 70 (CSA Standard C22.1** when installed in Canada) and with any local codes. To ensure the electrical safety of this appliance, it must be correctly connected to an efficient grounding system. The manufacturer is not responsible for any damages caused by the failure of the grounding system.

In the case of failure and/or poor unit performance, shut the unit down in the proper manner, disconnect the UNIT power supply and close the gas valve. Do not attempt any repair and call a qualified technician for service. The chiller should also be disconnected when not in use for a prolonged period of time.

The manufacturer's authorized service technicians, using only original replacement parts, must perform repairs to the product. Failure to adhere to this guideline may compromise the safety of the unit. To ensure the correct operation and efficiency of the unit, it is essential that qualified service technicians perform annual maintenance in accordance with the manufacturer's instructions.

If the unit is sold or transferred to another owner, this manual will be provided for use to the new owner and/or installer.

Under no circumstances should the unit be operated with any safety or electrical component bypassed or defective.

Do not use this appliance if any part has been under water. Immediately call a qualified service technician to inspect the appliance and to replace any part of the control system and any gas control, which has been under water.

Before starting the appliance:

A qualified service technician must verify that:

- The electric and gas supplies are the same as indicated on the rating plate
- The fuel supply and water distribution systems are water tight
- The appliance is supplied with the type of fuel for which it is preset
- The gas supply pressure conforms to the pressure indicated on the rating plate
- The gas supply system is appropriately designed for the gas rate needed by the unit, and equipped with all safety and control devices prescribed by standards in force.

WARNING

To guarantee the correct operation of the unit and avoid possible failures, **ALWAYS** turn off the unit by means of the thermostat or any switch that controls the operation of the unit.

NEVER turn off the unit by shutting off the power supply.

2. OVERVIEW AND TECHNICAL DATA

2.1 OVERVIEW

The High Efficiency Chillers ACF60-00 series are water chillers, equipped with an air-cooled condenser and designed for outdoor installation. The absorption cooling cycle is based upon a solution of water and ammonia for the production of chilled water (temperature of chilled water is given by Technical Tables).

The chilling system is fed by thermal energy provided by a gas burner, therefore the required electric energy is limited to driving the fan and pump motors (the only mechanical moving components of the unit). The evacuation of combustion gases occurs by mixing them with condenser air using an axial fan of the appliance. The combustion fuel is Natural Gas or LPG.

The **STANDARD** and **HT** versions are designed for the commercial and industrial air-conditioning applications in the hot climate areas.

The **TK** versions are designed for the air-conditioning and refrigeration of technological applications (for example, in the industrial process, that could require chilled water up to 24h a day).

The **LB** versions are designed for the low temperature refrigeration applications (for example cold rooms for food conservation).

ACF60-00 HR, "Heat Recovery". This is an ACF60-00 with a heat recovery system able to provide 60,500 Btu/hr of nominal cooling capacity when operating without the heat recovery system. With the heat recovery system, it can obtain a cooling capacity of 61,234 Btu/hr, at the same time providing 86,400 Btu/hr of heating capacity.

For further information see next paragraph, technical data.

ACF60-00 units are Natural Gas or LPG fired and supplied with 208 - 230V 60Hz single-phase electrical power.

ACF60-00 units could be controlled by DDC - Direct Digital Controller (available as Optional). DDC can control up to 16 single chillers.

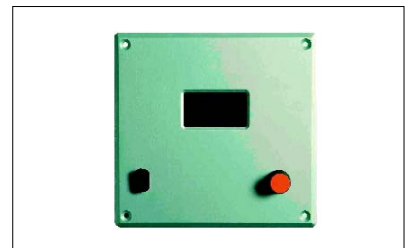

Figure 1 - Direct Digital Controller

CHILLER'S CONTROL AND SAFETY DEVICES

Electronic Control Board with integrated microprocessor controls the operation of the chiller.

High Temperature Limit Switch (manual reset) is located at the generator wall above the combustion chamber; the switch opens if the generator's sidewall temperature exceeds 330°F; the switch is manual reset. The switch can be reset when the generator sidewall temperature drops below 280°F.

Safety Relief Valve on the sealed circuit.

Differential Air Pressure Switch on the combustion circuit stops the burner ignition due to insufficient combustion air flow.

Ignition Control Box controls the burner ignition. Checks the differential air pressure switch and starts the pre-mixer blower. After 30 seconds of purging, the ignition control box opens the gas valve and starts the ignition transformer sparking at the burner for 8 seconds. If no flame is detected, the ignition control box will close the gas valve and retry lighting after an inter-purge period of 30 seconds. The ignition control box will try a total of three times to light. The unit will stop if no flame has been established or detected after the 3 tries.

Dual Gas Valve: two gas valves in the same housing, electrically controlled, which positively stops gas flow when either closes.

Flow Switch monitors the chilled water flow and shuts down the unit when the water flow stops or drops to an insufficient level.

2.2 GAS FIRED CHILLER OPERATION CYCLE

The fluid used in the cooling cycle is a solution of water and ammonia (see Figure 2). Ammonia is the **refrigerant** and water is the absorbing fluid. In the chiller's generator, the ammonia-water solution is heated to boiling by a burner producing both a vapor with a strong concentration of ammonia and a liquid solution with a low concentration of ammonia. Liquid solution with a low concentration of ammonia is called a "weak solution".

The ammonia vapor passes into the rectifier, which separates the water from the vapor. The hot and pressurized ammonia vapor exiting the rectifier enters the condenser where it is cooled and changed to a liquid.

The liquid ammonia is then brought to a lower pressure by means of a restrictor and further cooled in a "tube-in-tube" refrigerant heat exchanger. Finally, the liquid ammonia is reduced to a pressure of 39 to 60 psig and a temperature lower than 37°F by a second restrictor.

Under this low pressure and temperature condition, liquid ammonia enters the evaporator where the ammonia evaporates due to heat being removed from water returning from the user's required cooling application (thermal blowers, fan-coils, etc.) within the chilled water system.

The cold, low-pressure ammonia vapor exiting the evaporator exchanges heat with the liquid ammonia coming from the condenser in the refrigerant heat exchanger. The ammonia vapor then enters the "solution cooled absorber" where it comes into contact with "weak solution" from the generator that has been brought to a low pressure by means of a restrictor.

Inside the "solution cooled absorber" the absorption process starts, i.e. the dilution of ammonia vapor into the "weak solution". The absorption of ammonia vapor is an exothermic process. (i.e. heat is produced) To have the vapor completely absorbed by the solution, the solution exiting the "solution cooled absorber" must be further cooled in a portion of the condenser/absorber coils.

Once the absorption process is complete, the liquid solution contains a high concentration of ammonia, also called "strong solution". A hydraulically driven, diaphragm solution pump pumps the "strong solution" to the generator at high pressure.

As the "strong solution" is pumped to the generator, it passes through the coil of the rectifier and the solution cooled absorber (the GAX section) where it is preheated before entering the generator. The cycle then starts over.

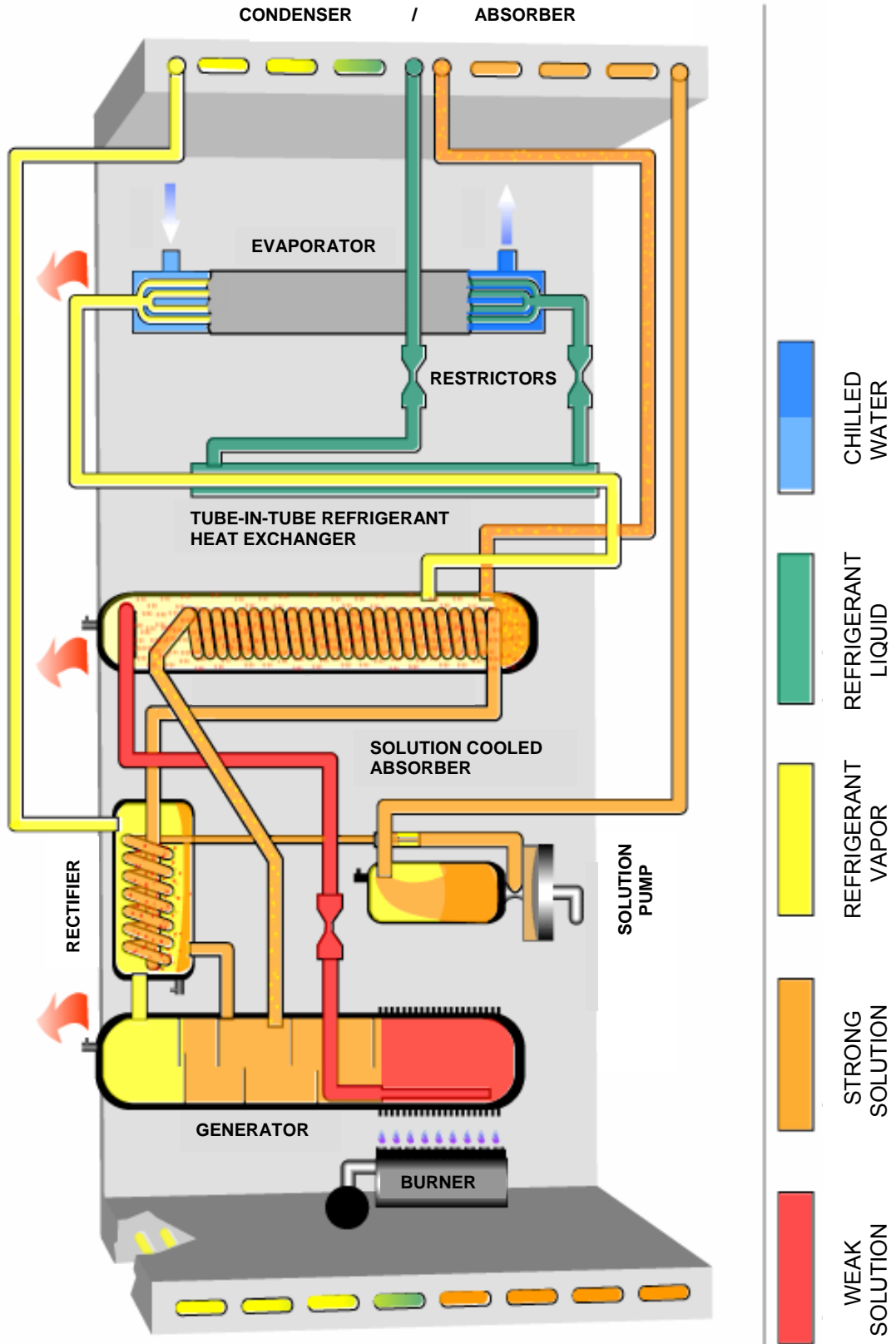

Figure 2– ABSORPTION REFRIGERANT CYCLE

2.3 TECHNICAL DATA: ACF60-00 (STANDARD, HR, HT, TK, LB VERSIONS)

STANDARD VERSION

| PERFORMANCE RATINGS ¹ | | UNITS | ACF60-00 |
|---|---------|------------------|--------------------------------|
| Cooling Capacity ² | Nominal | Btu/hr | 60,500 |
| Gas Input (HHV) | Nominal | Btu/hr | 94,900 |
| Ambient Operating Temperature | Maximum | °F | 120 |
| | Minimum | °F | 32 |
| Condenser Air Flow ³ | Nominal | CFM | 6,000 |
| | Minimum | CFM | 2,000 |
| Inlet (to the unit) Chilled Water Temperature | Maximum | °F | 113 |
| Outlet (to plant) Chilled Water Temperature | Minimum | °F | 37.4 |
| Chilled Water Flow | Nominal | GPM | 12.2 |
| | Maximum | | 14.1 |
| | Minimum | | 11.0 |
| Internal Pressure Drop | | Feet of Head | 9.7 |
| | | psi _g | 4.2 |
| ELECTRICAL RATINGS | | | |
| Required Voltage, 60 Hz, Single Phase ⁴ | | V | 208 - 230 |
| Condenser Fan Motor HP (Variable Speed) | Nominal | - | 1/2 |
| | | A | 3.1 / 6.2 |
| Hydraulic Pump Motor HP | Nominal | - | 1/2 |
| | | A | 3.1 / 24.2 |
| Premix Blower Motor HP | Nominal | - | 1/50 |
| | | A | .55 / .75 |
| Total Electrical Operating Consumption ⁵ (Unit only) | | kW | .75 |
| Minimum Circuit Ampacity (MCA) (Unit only) | | A | 9.88 |
| Maximum Over Current Protection (MOCP) Qty (2) - Field Supplied | | A | 15 |
| PHYSICAL DATA | | | |
| Refrigerant Type | | - | R717 |
| Unit Chilled Water Volume ⁶ | | Gallons | 0.79 |
| Chilled Water Entering and Leaving Connections ⁷ | | FPT | 1 |
| Gas Inlet Connection | | FPT | 1/2 |
| Electrical Entrance Knockouts, Diameter | | Inches | 7/8 |
| Shipping Weight | | Pounds | 795 |
| Operating Weight | | Pounds | 750 |
| Dimensions | Width | Inches | 33 ¹ / ₂ |
| | Length | | 48 ¹ / ₂ |
| | Height | | 50 ³ / ₄ |

Table 1 – ACF60-00 TECHNICAL DATA

Notes:

1. All illustrations and specifications contained herein are based on the latest information available at the time of publication approval. Robur reserves the right to make changes at any time without notice, in materials, specifications, and models or to discontinue models.
2. Capacity at standard conditions of 95°F ambient temperature. Chilled water Outlet temperature 45°F, chilled water Inlet temperature 55°F. Actual capacity will vary with ambient (condenser) air temperature and leaving water temperature. Capacity characteristics are shown in the table below. Interpolations between tabled values are permissible, but do not extrapolate. For capacities at ambient temperatures higher than in table, contact Robur or your authorized distributor.
3. Fan speed is reduced when external temperature is less than 91.4°F.
4. Units are factory-wired for 208-230 volts operation.
5. May vary by ±10% as a function of both power supply and electrical motor input tolerance.
6. "Chilled Water" refers to a solution of quality tap water and 10% by volume of inhibited permanent antifreeze. Higher antifreeze concentrations may be required in certain applications.
7. Mono-ethylene glycol causes corrosion phenomenon in galvanized metal pipes.

COOLING CAPACITY in Btu/hr

| AMBIENT AIR TEMPERATURE (°F) | OUTLET CHILLED WATER (°F) | | | |
|------------------------------|---------------------------|--------|--------|--------|
| | 37.4 | 41.0 | 44.6 | 48.2 |
| 32 | 59,307 | 59,912 | 61,123 | 62,323 |
| 41 | 59,307 | 59,912 | 61,123 | 62,333 |
| 50 | 59,307 | 59,912 | 61,123 | 62,323 |
| 59 | 59,307 | 59,912 | 61,123 | 62,333 |
| 68 | 59,307 | 59,912 | 61,123 | 62,323 |
| 77 | 58,701 | 59,912 | 61,123 | 62,333 |
| 86 | 54,465 | 59,307 | 61,123 | 62,333 |
| 95 | 40,546 | 52,650 | 60,517 | 61,727 |
| 104 | - | - | 53,255 | 56,281 |
| 113 | - | - | 40,546 | 47,203 |
| 120 | - | - | - | 39,336 |

Table 2 – ACF60-00 COOLING CAPACITY

HT VERSION

| PERFORMANCE RATINGS¹ | | UNITS | ACF60-00 HT |
|---|---------|------------------|--------------------------------|
| Cooling Capacity ² | Nominal | Btu/hr | 58,400 |
| Gas Input (HHV) | Nominal | Btu/hr | 94,900 |
| Ambient Operating Temperature | Maximum | °F | 131 |
| | Minimum | °F | 32 |
| Condenser Air Flow ³ | Nominal | CFM | 6,000 |
| | Minimum | CFM | 2,000 |
| Inlet (to the unit) Chilled Water Temperature | Maximum | °F | 113 |
| Outlet (to plant) Chilled Water Temperature | Minimum | °F | 41 |
| Chilled Water Flow | Nominal | GPM | 11.8 |
| | Maximum | | 14.1 |
| | Minimum | | 11.0 |
| Internal Pressure Drop | | Feet of Head | 9.1 |
| | | psi _g | 3.9 |
| ELECTRICAL RATINGS | | | |
| Required Voltage, 60 Hz, Single Phase ⁴ | | V | 208 - 230 |
| Condenser Fan Motor HP (Variable Speed) | Nominal | - | 1/2 |
| | | A | 3.1 / 6.2 |
| Hydraulic Pump Motor HP | Nominal | - | 1/2 |
| | | A | 3.1 / 24.2 |
| Premix Blower Motor HP | Nominal | - | 1/50 |
| | | A | .55 / .75 |
| Total Electrical Operating Consumption ⁵ (Unit only) | | kW | .75 |
| Minimum Circuit Ampacity (MCA) (Unit only) | | A | 9.88 |
| Maximum Over Current Protection (MOCP) Qty (2) - Field Supplied | | A | 15 |
| PHYSICAL DATA | | | |
| Refrigerant Type | | - | R717 |
| Unit Chilled Water Volume ⁶ | | Gallons | 0.79 |
| Chilled Water Entering and Leaving Connections ⁷ | | FPT | 1 |
| Gas Inlet Connection | | FPT | 1/2 |
| Electrical Entrance Knockouts, Diameter | | Inches | 7/8 |
| Shipping Weight | | Pounds | 860 |
| Operating Weight | | Pounds | 816 |
| Dimensions | Width | Inches | 33 ¹ / ₂ |
| | Length | | 48 ¹ / ₂ |
| | Height | | 50 ³ / ₄ |

Table 3 – ACF60-00 HT TECHNICAL DATA

Notes:

1. All illustrations and specifications contained herein are based on the latest information available at the time of publication approval. Robur reserves the right to make changes at any time without notice, in materials, specifications, and models or to discontinue models.
2. Capacity at standard conditions of 95°F ambient temperature. Chilled water Outlet temperature 45°F, chilled water Inlet temperature 55°F. Actual capacity will vary with ambient (condenser) air temperature and leaving water temperature. Capacity characteristics are shown in the table below. Interpolations between tabled values are permissible, but do not extrapolate. For capacities at ambient temperatures higher than in table, contact Robur or your authorized distributor.
3. Fan speed is reduced when external temperature is less than 91.4°F.
4. Units are factory-wired for 208-230 volts operation.
5. May vary by $\pm 10\%$ as a function of both power supply and electrical motor input tolerance.
6. "Chilled Water" refers to a solution of quality tap water and 10% by volume of inhibited permanent antifreeze. Higher antifreeze concentrations may be required in certain applications.
7. Mono-ethylene glycol causes corrosion phenomenon in galvanized metal pipes.

COOLING CAPACITY in Btu/hr

| AMBIENT AIR TEMPERATURE (°F) | OUTLET CHILLED WATER (°F) | | | | |
|------------------------------|---------------------------|--------|--------|--------|--------|
| | 41.0 | 44.6 | 50.0 | 54.5 | 57.2 |
| 32.0 | 59,637 | 59,637 | 59,637 | 59,637 | 60,222 |
| 35.6 | 59,637 | 59,637 | 59,637 | 59,637 | 60,222 |
| 39.2 | 59,637 | 59,637 | 59,637 | 59,637 | 60,222 |
| 42.8 | 59,637 | 59,637 | 59,637 | 59,637 | 60,222 |
| 46.4 | 59,637 | 59,637 | 59,637 | 59,637 | 60,222 |
| 50.0 | 59,637 | 59,637 | 59,637 | 59,637 | 60,222 |
| 53.6 | 59,637 | 59,637 | 59,637 | 59,637 | 60,222 |
| 57.2 | 59,637 | 59,637 | 59,637 | 59,637 | 60,222 |
| 60.8 | 59,637 | 59,637 | 59,637 | 59,637 | 60,222 |
| 64.4 | 59,637 | 59,637 | 59,637 | 59,637 | 60,222 |
| 68.0 | 59,637 | 59,637 | 59,637 | 59,637 | 60,222 |
| 71.6 | 59,637 | 59,637 | 59,637 | 59,637 | 60,222 |
| 75.2 | 59,637 | 59,637 | 59,637 | 59,637 | 60,222 |
| 78.8 | 59,053 | 59,637 | 59,637 | 59,637 | 60,222 |
| 82.4 | 59,053 | 59,637 | 59,637 | 59,637 | 60,222 |
| 86.0 | 59,053 | 59,637 | 59,637 | 59,637 | 60,222 |
| 89.6 | 57,883 | 59,637 | 59,637 | 59,637 | 60,222 |
| 93.2 | 56,129 | 59,053 | 59,053 | 59,053 | 59,637 |
| 95.0 | 54,960 | 58,368 | 58,468 | 59,053 | 59,637 |
| 96.8 | 53,791 | 57,883 | 58,468 | 58,468 | 59,637 |
| 100.4 | 50,867 | 56,714 | 57,883 | 57,883 | 59,053 |
| 104.0 | 47,944 | 54,375 | 56,714 | 57,299 | 58,468 |
| 107.6 | - | 51,452 | 54,960 | 56,714 | 57,883 |
| 111.2 | - | 47,944 | 53,206 | 55,545 | 56,714 |
| 114.8 | - | - | 50,282 | 53,791 | 55,545 |
| 118.4 | - | - | 46,774 | 50,867 | 53,206 |
| 131.0 | - | - | - | 47,359 | 50,282 |

Table 4 – ACF60-00 HT COOLING CAPACITY

TK VERSION

| PERFORMANCE RATINGS¹ | | UNITS | ACF60-00 TK |
|--|---------|----------------------------------|--------------------------------|
| Cooling Capacity ² | Nominal | Btu/hr | 60,500 |
| Gas Input (HHV) | Nominal | Btu/hr | 94,900 |
| Ambient Operating Temperature | Maximum | °F | 120 |
| | Minimum | °F | 10.4 |
| Condenser Air Flow ³ | Nominal | CFM | 6,000 |
| | Minimum | CFM | 2,000 |
| Inlet (to the unit) Chilled Water Temperature | Maximum | °F | 113 |
| Outlet (to plant) Chilled Water Temperature | Minimum | °F | 37.4 |
| Chilled Water Flow | Nominal | GPM | 12.2 |
| | Maximum | | 14.1 |
| | Minimum | | 11.0 |
| Internal Pressure Drop | | Feet of Head psi _g | 9.7 |
| | | | 4.2 |
| ELECTRICAL RATINGS | | | |
| Required Voltage, 60 Hz, Single Phase ⁴ | | V | 208 - 230 |
| Condenser Fan Motor HP (Variable Speed) | Nominal | - | 1/2 |
| | | A | 3.1 / 6.2 |
| Hydraulic Pump Motor HP Full Load / Locked Rotor | Nominal | - | 1/2 |
| | | A | 3.1 / 24.2 |
| Premix Blower Motor HP Full Load / Locked Rotor | Nominal | - | 1/50 |
| | | A | .55 / .75 |
| Total Electrical Operating Consumption ⁵ (Unit only) | | kW | .75 |
| Minimum Circuit Ampacity (MCA) (Unit only) | | A | 9.88 |
| Maximum Over Current Protection (MOCP) Qty (2) - Field Supplied | | A | 15 |
| PHYSICAL DATA | | | |
| Refrigerant Type | | - | R717 |
| Unit Chilled Water Volume ⁶ | | Gallons | 0.79 |
| Chilled Water Entering and Leaving Connections ⁷ | | FPT | 1 |
| Gas Inlet Connection | | FPT | 1/2 |
| Electrical Entrance Knockouts, Diameter | | Inches | 7/8 |
| Shipping Weight | | Pounds | 860 |
| Operating Weight | | Pounds | 816 |
| Dimensions | Width | Inches | 33 ¹ / ₂ |
| | Length | | 48 ¹ / ₂ |
| | Height | | 50 ³ / ₄ |

Table 5 – ACF60-00 TK TECHNICAL DATA

Notes:

1. All illustrations and specifications contained herein are based on the latest information available at the time of publication approval. Robur reserves the right to make changes at any time without notice, in materials, specifications, and models or to discontinue models.
2. Capacity at standard conditions of 95°F ambient temperature. Chilled water Outlet temperature 45°F, chilled water Inlet temperature 55°F. Actual capacity will vary with ambient (condenser) air temperature and leaving water temperature. Capacity characteristics are shown in the table below. Interpolations between tabled values are permissible, but do not extrapolate. For capacities at ambient temperatures higher than in table, contact Robur or your authorized distributor.
3. Fan speed is reduced when external temperature is less than 91.4°F.
4. Units are factory-wired for 208-230 volts operation.
5. May vary by ±10% as a function of both power supply and electrical motor input tolerance.
6. "Chilled Water" refers to a solution of quality tap water and 10% by volume of inhibited permanent antifreeze. Higher antifreeze concentrations may be required in certain applications.
7. Mono-ethylene glycol causes corrosion phenomenon in galvanized metal pipes.

COOLING CAPACITY in Btu/hr

| AMBIENT AIR TEMPERATURE (°F) | OUTLET CHILLED WATER (°F) | | | |
|------------------------------|---------------------------|--------|--------|--------|
| | 37.4 | 41.0 | 44.6 | 48.2 |
| 10.4 | 71,410 | 71,410 | 72,015 | 72,620 |
| 17.6 | 70,805 | 70,805 | 71,410 | 72,015 |
| 24.8 | 70,200 | 70,200 | 70,200 | 71,410 |
| 32.0 | 69,595 | 69,595 | 69,595 | 70,200 |
| 39.2 | 68,989 | 68,989 | 68,989 | 69,595 |
| 46.4 | 67,779 | 68,384 | 68,384 | 68,989 |
| 53.6 | 67,779 | 67,779 | 67,779 | 68,384 |
| 60.8 | 67,174 | 67,174 | 67,779 | 67,779 |
| 68.0 | 65,964 | 65,964 | 67,174 | 67,174 |
| 75.2 | 64,148 | 64,148 | 66,569 | 66,569 |
| 82.4 | 59,307 | 61,727 | 65,358 | 65,358 |
| 89.6 | 51,439 | 57,491 | 62,938 | 64,148 |
| 95.0 | 41,757 | 52,650 | 60,517 | 62,333 |
| 100.4 | - | - | 56,886 | 59,912 |
| 107.6 | - | - | 50,229 | 55,070 |
| 113.0 | - | - | - | 49,624 |
| 120.0 | - | - | - | 42,057 |

Table 6 – ACF60-00 TK COOLING CAPACITY

ACF60-00 UNIT INTERNAL PRESSURE DROP (Standard, HT, TK versions)

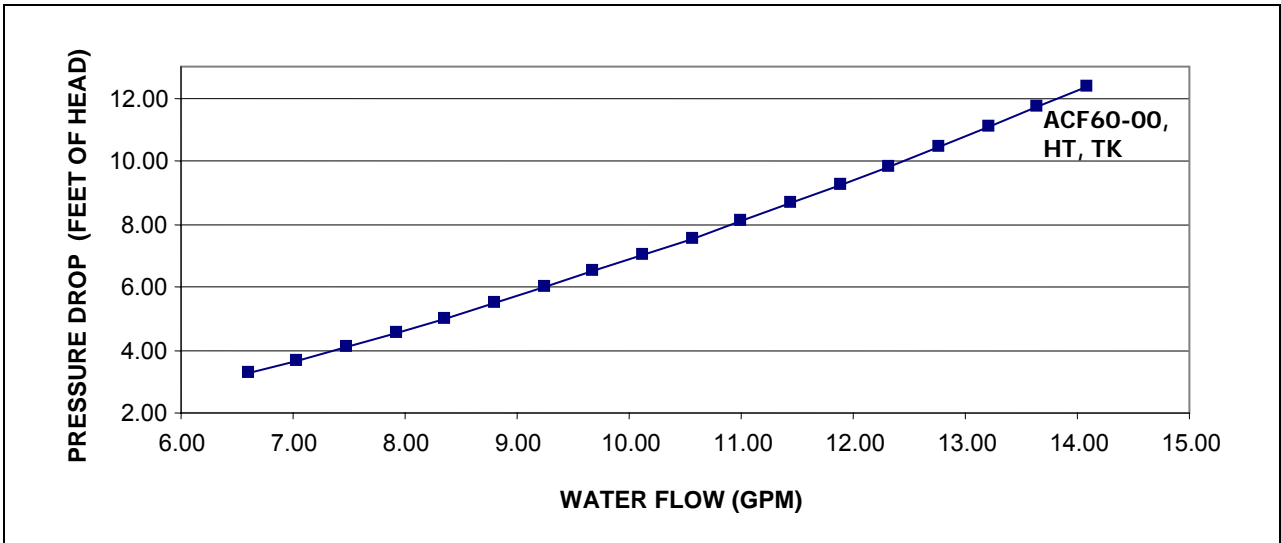

Graph 1- UNIT PRESSURE DROP AS A FUNCTION OF WATER FLOW, OUTLET WATER TEMPERATURE 44.6 °F

LB VERSIONS

| PERFORMANCE RATINGS¹ | | UNITS | ACF60-00 LB |
|--|---------|----------------------------------|--------------------------------|
| Cooling Capacity ² | Nominal | Btu/hr | 45,400 |
| Gas Input (HHV) | Nominal | Btu/hr | 94,900 |
| Ambient Operating Temperature | Maximum | °F | 120 |
| | Minimum | °F | 10.4 |
| Condenser Air Flow ³ | Nominal | CFM | 6,000 |
| | Minimum | CFM | 2,000 |
| Inlet (to the unit) Chilled Water Temperature | Maximum | °F | 113 |
| Outlet (to plant) Chilled Water Temperature | Minimum | °F | 14 |
| Chilled Water Flow | Nominal | GPM | 11.4 |
| | Maximum | | 12.8 |
| | Minimum | | 10.1 |
| Internal Pressure Drop | | Feet of Head psi _g | 14.1 |
| | | | 6.1 |
| ELECTRICAL RATINGS | | | |
| Required Voltage, 60 Hz, Single Phase ⁴ | | V | 208 - 230 |
| Condenser Fan Motor HP (Variable Speed) | Nominal | - | 1/2 |
| | | A | 3.1 / 6.2 |
| Hydraulic Pump Motor HP Full Load / Locked Rotor | Nominal | - | 1/2 |
| | | A | 3.1 / 24.2 |
| Premix Blower Motor HP Full Load / Locked Rotor | Nominal | - | 1/50 |
| | | A | .55 / .75 |
| Total Electrical Operating Consumption ⁵ (Unit only) | | kW | .75 |
| Minimum Circuit Ampacity (MCA) (Unit only) | | A | 9.88 |
| Maximum Over Current Protection (MOCP) Qty (2) - Field Supplied | | A | 15 |
| PHYSICAL DATA | | | |
| Refrigerant Type | | - | R717 |
| Unit Chilled Water Volume | | Gallons | 0.79 |
| Chilled Water Entering and Leaving Connections ⁶ | | FPT | 1 |
| Gas Inlet Connection | | FPT | 1/2 |
| Electrical Entrance Knockouts, Diameter | | Inches | 7/8 |
| Shipping Weight | | Pounds | 860 |
| Operating Weight | | Pounds | 816 |
| Dimensions | Width | Inches | 33 ¹ / ₂ |
| | Length | | 48 ¹ / ₂ |
| | Height | | 50 ³ / ₄ |

Table 7 – ACF60-00 LB TECHNICAL DATA

Notes:

1. All illustrations and specifications contained herein are based on the latest information available at the time of publication approval. Robur reserves the right to make changes at any time without notice, in materials, specifications, and models or to discontinue models.
2. Capacity at standard conditions of 95°F ambient temperature. Chilled water Outlet temperature (40% mono-ethylene glycol) 23°F, chilled water Inlet temperature 32°F. Actual capacity will vary with ambient (condenser) air temperature and leaving water temperature. Capacity characteristics are shown in the table below. Interpolations between tabled values are permissible, but do not extrapolate. For capacities at ambient temperatures higher than in table, contact Robur or your authorized distributor.
3. Fan speed is reduced when external temperature is less than 91.4°F.
4. Units are factory-wired for 208-230 volts operation.
5. May vary by $\pm 10\%$ as a function of both power supply and electrical motor input tolerance.
6. Mono-ethylene glycol causes corrosion phenomenon in galvanized metal pipes.

COOLING CAPACITY in Btu/hr

| AMBIENT AIR TEMPERATURE (°F) | OUTLET CHILLED WATER (°F) | | | | |
|------------------------------|---------------------------|--------|--------|--------|--------|
| | 14.0 | 19.4 | 23.0 | 28.4 | 32.0 |
| 23.0 | 52,007 | 52,217 | 52,426 | 52,801 | 53,176 |
| 24.8 | 52,007 | 52,217 | 52,426 | 52,801 | 53,176 |
| 26.6 | 52,007 | 52,217 | 52,426 | 52,801 | 53,176 |
| 28.4 | 52,007 | 52,217 | 52,426 | 52,801 | 53,176 |
| 30.2 | 52,007 | 52,217 | 52,426 | 52,801 | 53,176 |
| 32.0 | 52,007 | 52,217 | 52,426 | 52,801 | 53,176 |
| 33.8 | 52,007 | 52,217 | 52,426 | 52,801 | 53,176 |
| 35.6 | 52,007 | 52,217 | 52,426 | 52,801 | 53,176 |
| 37.4 | 52,007 | 52,217 | 52,426 | 52,801 | 53,176 |
| 39.2 | 52,007 | 52,217 | 52,426 | 52,801 | 53,176 |
| 41.0 | 52,007 | 52,217 | 52,426 | 52,801 | 53,176 |
| 42.8 | 52,007 | 52,217 | 52,426 | 52,801 | 53,176 |
| 44.6 | 52,007 | 52,217 | 52,426 | 52,801 | 53,176 |
| 46.4 | 52,007 | 52,200 | 52,392 | 52,784 | 53,176 |
| 48.2 | 52,007 | 52,183 | 52,358 | 52,767 | 53,176 |
| 50.0 | 52,007 | 52,166 | 52,324 | 52,750 | 53,176 |
| 51.8 | 51,965 | 52,127 | 52,290 | 52,733 | 53,176 |
| 53.6 | 51,904 | 52,080 | 52,256 | 52,716 | 53,176 |
| 55.4 | 51,822 | 52,022 | 52,221 | 52,699 | 53,176 |
| 57.2 | 51,718 | 51,952 | 52,187 | 52,681 | 53,176 |
| 59.0 | 51,588 | 51,884 | 52,181 | 52,678 | 53,176 |
| 60.8 | 51,430 | 51,793 | 52,157 | 52,666 | 53,176 |
| 62.6 | 51,241 | 51,677 | 52,113 | 52,644 | 53,176 |
| 64.4 | 51,020 | 51,533 | 52,047 | 52,610 | 53,172 |
| 66.2 | 50,763 | 51,360 | 51,957 | 52,563 | 53,169 |
| 68.0 | 50,469 | 51,155 | 51,841 | 52,503 | 53,166 |
| 69.8 | 50,134 | 50,915 | 51,696 | 52,423 | 53,149 |
| 71.6 | 49,757 | 50,638 | 51,520 | 52,314 | 53,107 |
| 73.4 | 49,334 | 50,322 | 51,311 | 52,174 | 53,038 |
| 75.2 | 48,864 | 49,965 | 51,067 | 52,002 | 52,937 |
| 77.0 | 48,343 | 49,564 | 50,785 | 51,795 | 52,805 |

| AMBIENT AIR TEMPERATURE (°F) | OUTLET CHILLED WATER (°F) | | | | |
|------------------------------|---------------------------|--------|--------|--------|--------|
| | 14.0 | 19.4 | 23.0 | 28.4 | 32.0 |
| 78.8 | 47,771 | 49,117 | 50,464 | 51,551 | 52,637 |
| 80.6 | 47,143 | 48,622 | 50,101 | 51,267 | 52,432 |
| 82.4 | 46,458 | 48,076 | 49,694 | 50,941 | 52,188 |
| 84.2 | 45,713 | 47,476 | 49,240 | 50,571 | 51,901 |
| 86.0 | 44,905 | 46,822 | 48,738 | 50,155 | 51,571 |
| 87.8 | 44,033 | 46,109 | 48,186 | 49,690 | 51,194 |
| 89.6 | 43,093 | 45,337 | 47,580 | 49,174 | 50,768 |
| 91.4 | 42,084 | 44,502 | 46,919 | 48,605 | 50,291 |
| 93.2 | 41,003 | 43,602 | 46,201 | 47,981 | 49,760 |
| 95.0 | 39,847 | 42,635 | 45,400 | 47,299 | 49,174 |
| 96.8 | 38,614 | 41,599 | 44,584 | 46,557 | 48,530 |
| 98.6 | 37,302 | 40,491 | 43,681 | 45,753 | 47,825 |
| 100.4 | 35,907 | 39,309 | 42,711 | 44,884 | 47,057 |
| 102.2 | 34,428 | 38,051 | 41,673 | 43,949 | 46,225 |
| 104.0 | 32,863 | 36,713 | 40,564 | 42,945 | 45,325 |
| 105.8 | 31,208 | 35,295 | 39,383 | 41,869 | 44,356 |
| 107.6 | 29,461 | 33,794 | 38,126 | 40,720 | 43,314 |
| 109.4 | 27,620 | 32,206 | 36,793 | 39,496 | 42,198 |
| 111.2 | 25,682 | 30,531 | 35,379 | 38,193 | 41,006 |
| 113.0 | 23,645 | 28,765 | 33,885 | 36,810 | 39,735 |
| 120.0 | - | - | 28,004 | 31,587 | 35,176 |

Table 8 – ACF60-00 LB COOLING CAPACITY

ACF60-00 LB UNIT INTERNAL PRESSURE DROP

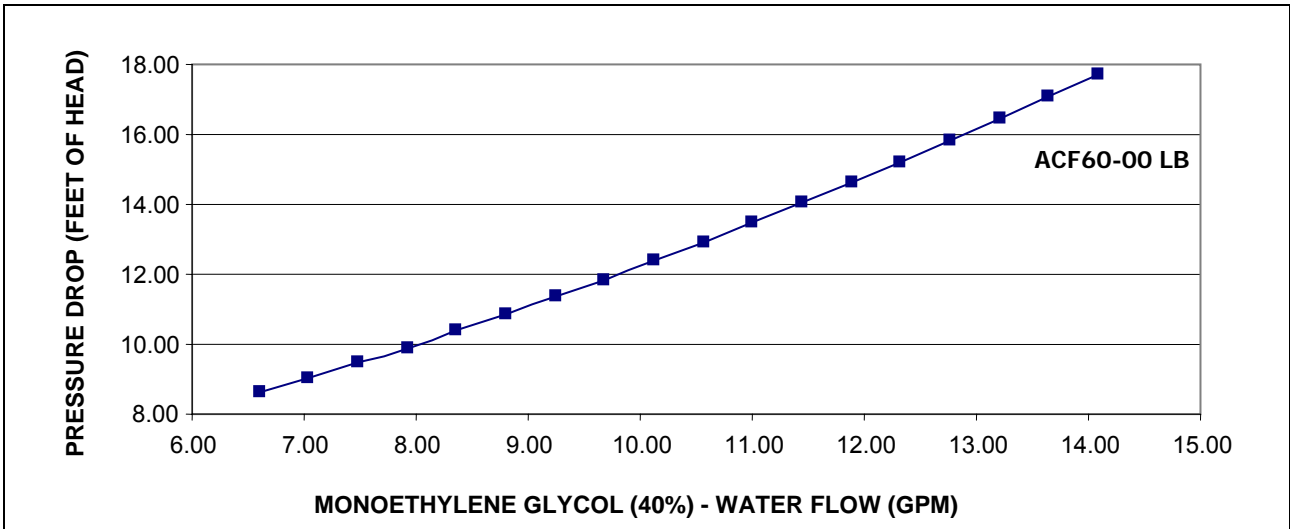

Graph 2 - ACF60-00 LB PRESSURE DROP

HR VERSION

| PERFORMANCE RATINGS ¹ | | UNITS | ACF60-00 HR |
|--|---------|------------------|-------------|
| Cooling Capacity ² Air conditioning only (no recovery) | Nominal | Btu/hr | 60,500 |
| Cooling Capacity ³ Air conditioning + recovery | Nominal | Btu/hr | 61,240 |
| Heat Capacity ⁴ | | Btu/hr | 86,400 |
| Gas Input (HHV) | Nominal | Btu/hr | 94,900 |
| Ambient Operating Temperature | Maximum | °F | 120 |
| | Minimum | °F | 32 |
| Condenser Air Flow ⁵ | Nominal | CFM | 6,000 |
| | Minimum | CFM | 2,000 |
| Inlet (to the unit) Chilled Water Temperature | Maximum | °F | 113 |
| Outlet (to plant) Chilled Water Temperature | Minimum | °F | 37.4 |
| Chilled Water Flow | Nominal | GPM | 12.2 |
| | Maximum | | 14.1 |
| | Minimum | | 11.0 |
| Recovery System Hot Water Flow rate ($\Delta T=18^{\circ}F$) | Nominal | GPM | 9.6 |
| | Maximum | | 0 |
| | Minimum | | 11.0 |
| Internal Pressure Drop | | Feet of Head | 9.7 |
| | | psi _g | 4.2 |
| Pressure Drop inside Recovery System | Nominal | Feet of Head | 4.34 |
| | | psi _g | 3 |
| ELECTRICAL RATINGS | | | |
| Required Voltage, 60 Hz, Single Phase ⁶ | | V | 208 - 230 |
| Condenser Fan Motor HP (Variable Speed) | Nominal | - | 1/2 |
| | | A | 3.1 / 6.2 |
| Hydraulic Pump Motor HP | Nominal | - | 1/2 |
| | | A | 3.1 / 24.2 |
| Premix Blower Motor HP | Nominal | - | 1/50 |
| | | A | .55 / .75 |
| Total Electrical Operating Consumption ⁷ (Unit only) | | kW | .75 |
| Minimum Circuit Ampacity (MCA) (Unit only) | | A | 9.88 |
| Maximum Over Current Protection (MOCP) Qty (2) - Field Supplied | | A | 15 |

| PHYSICAL DATA | | | |
|---|--------|---------|--------------------------------|
| Refrigerant Type | | - | R717 |
| Unit Chilled Water Volume ⁸ | | Gallons | 0.79 |
| Water capacity of heat recovery | | Gallons | 0.79 |
| Water Entering and Leaving Connections ⁹ | | FPT | 1 |
| Gas Inlet Connection | | FPT | 1/2 |
| Electrical Entrance Knockouts, Diameter | | Inches | 7/8 |
| Shipping Weight | | Pounds | 860 |
| Operating Weight | | Pounds | 815 |
| Dimensions | Width | | 33 ¹ / ₂ |
| | Length | Inches | 48 ¹ / ₂ |
| | Height | | 50 ³ / ₄ |

Table 9 – ACF60-00 HR TECHNICAL DATA

Notes:

1. All illustrations and specifications contained herein are based on the latest information available at the time of publication approval. Robur reserves the right to make changes at any time without notice, in materials, specifications, and models or to discontinue models.
2. Cooling capacity at standard conditions (no recovery): ambient temperature 95°F. Chilled water Outlet temperature 45°F, chilled water Inlet temperature 55°F. Actual capacity will vary with ambient (condenser) air temperature and leaving water temperature. Capacity characteristics are shown in the table below (Table 10). Interpolations between tabled values are permissible, but do not extrapolate. For capacities at ambient temperatures higher than in table, contact Robur or your authorized distributor.
3. Cooling capacity at standard conditions (with recovery): ambient temperature 95°F. Chilled water Outlet temperature 45°F; heat recovery system water temperature - delivery 122°F – return 104°F. For condition other than the nominal conditions, apply the cooling capacity correction factors seen in Table 11, page 23.
4. Cooling capacity at standard conditions (with recovery): ambient temperature 95°F. Chilled water Outlet temperature 45°F; heat recovery system water temperature - delivery 122°F – return 104°F. For condition other than the nominal conditions, apply the heating capacity correction factors seen in Table 12, Table 13, Table 14, Table 15, Table 16, from page 24 to page 25.
5. Fan speed is reduced when external temperature is less than 91.4°F.
6. Units are factory-wired for 208-230 volts operation.
7. May vary by ±10% as a function of both power supply and electrical motor input tolerance.
8. "Chilled Water" refers to a solution of quality tap water and 10% by volume of inhibited permanent antifreeze. Higher antifreeze concentrations may be required in certain applications.
9. Mono-ethylene glycol causes corrosion phenomenon in galvanized metal pipes.

ACF60-00 HR – COOLING CAPACITY CORRECTION FACTORS [Btu/hr]

| OPERATIONAL MODE: AIR CONDITIONING ONLY | | | | |
|---|-------------------------------|------|-------------|------|
| EXTERNAL AIR TEMPERATURE °F | WATER DELIVERY TEMPERATURE °F | | | |
| | 37.4 | 41 | 44.6 | 48.2 |
| 32 | 0.98 | 0.99 | 1.01 | 1.03 |
| 41 | 0.98 | 0.99 | 1.01 | 1.03 |
| 50 | 0.98 | 0.99 | 1.01 | 1.03 |
| 59 | 0.98 | 0.99 | 1.01 | 1.03 |
| 68 | 0.98 | 0.99 | 1.01 | 1.03 |
| 77 | 0.97 | 0.99 | 1.01 | 1.03 |
| 86 | 0.90 | 0.98 | 1.01 | 1.03 |
| 95 | 0.67 | 0.87 | 1.00 | 1.02 |
| 104 | — | — | 0.88 | 0.93 |
| 113 | — | — | 0.67 | 0.78 |

Table 10 – ACF60-00 HR - Cooling capacity multiplication correctional factors in air conditioning mode (no recovery) for external air temperatures and water flow rates different from the nominal values reported in the table.

ACF60-00 HR – COOLING CAPACITY CORRECTION FACTORS [Btu/hr]

| OPERATIONAL MODE: AIR CONDITIONING + RECOVERY | | | | |
|---|-------------------------------|------|-------------|------|
| EXTERNAL AIR TEMPERATURE °F | WATER DELIVERY TEMPERATURE °F | | | |
| | 37.4 | 41 | 44.6 | 48.2 |
| 32 | 0.97 | 0.98 | 1.00 | 1.02 |
| 41 | 0.97 | 0.98 | 1.00 | 1.02 |
| 50 | 0.97 | 0.98 | 1.00 | 1.02 |
| 59 | 0.97 | 0.98 | 1.00 | 1.02 |
| 68 | 0.97 | 0.98 | 1.00 | 1.02 |
| 77 | 0.96 | 0.98 | 1.00 | 1.02 |
| 86 | 0.89 | 0.97 | 1.00 | 1.02 |
| 95 | 0.73 | 0.91 | 1.00 | 1.02 |
| 104 | — | 0.89 | 0.95 | 0.96 |
| 113 | — | — | 0.80 | 0.85 |

Table 11 – ACF60-00 HR - Cooling capacity multiplication correctional factors in air conditioning+recovery mode for external air temperatures and water flow rates different from the nominal values reported in the table.

**ACF60-00 HR – HEATING CAPACITY OF THE HEAT RECOVERY UNIT [Btu/hr]
(output AT THE HEAT RECOVERY UNIT variable)**

| HEAT CAPACITY Btu/hr (Output = 2.2 GPM) | | | | | | | |
|---|-----------------------------|--------|--------|--------|--------|--------|--------|
| RECOVERY SYSTEM HOT WATER RETURN TEMPERATURE °F | EXTERNAL AIR TEMPERATURE °F | | | | | | |
| | 59 | 68 | 77 | 86 | 95 | 104 | 113 |
| 50 | 92,210 | 92,893 | 93,576 | 93,917 | 95,283 | 96,308 | 97,333 |
| 68 | 72,743 | 75,134 | 76,978 | 78,549 | 80,188 | 83,330 | 85,379 |
| 86 | 52,628 | 55,667 | 58,570 | 61,644 | 65,162 | 68,577 | 72,231 |
| 104 | 35,859 | 39,275 | 42,007 | 46,071 | 50,954 | 55,667 | 61,507 |
| 122 | 21,857 | 24,248 | 27,356 | 31,761 | 37,567 | 43,714 | 50,818 |
| 140 | 9,563 | 12,226 | 15,368 | 18,783 | 25,033 | 31,420 | 40,982 |
| 158 | — | — | 8,196 | 8,982 | 13,831 | 21,003 | 30,395 |

Table 12 – ACF60-00 HR - Heat capacity of the heat recovery unit for condition other than the nominal conditions; with output = 2.2 GPM.

| HEAT CAPACITY Btu/hr (Output = 4.4 GPM) | | | | | | | |
|---|-----------------------------|--------|---------|---------|---------|--------|---------|
| RECOVERY SYSTEM HOT WATER RETURN TEMPERATURE °F | EXTERNAL AIR TEMPERATURE °F | | | | | | |
| | 59 | 68 | 77 | 86 | 95 | 104 | 113 |
| 68 | 92,210 | 99,040 | 102,797 | 106,895 | 109,286 | — | — |
| 86 | 71,719 | 78,208 | 83,604 | 85,755 | 89,546 | 95,625 | 102,455 |
| 104 | 47,983 | 54,643 | 61,473 | 65,162 | 71,719 | 78,549 | 85,584 |
| 122 | 27,765 | 34,083 | 41,426 | 45,149 | 53,004 | 59,868 | 65,640 |
| 140 | 10,246 | 16,051 | 21,447 | 25,682 | 34,152 | 40,299 | 46,105 |
| 158 | — | — | 8,538 | 11,953 | 19,330 | 23,906 | 31,078 |

Table 13 – ACF60-00 HR - Heat capacity of the heat recovery unit for condition other than the nominal conditions; with output = 4.4 GPM.

| HEAT CAPACITY Btu/hr (Output = 6.6 GPM) | | | | | | | |
|---|-----------------------------|---------|---------|--------|---------|---------|---------|
| RECOVERY SYSTEM HOT WATER RETURN TEMPERATURE °F | EXTERNAL AIR TEMPERATURE °F | | | | | | |
| | 59 | 68 | 77 | 86 | 95 | 104 | 113 |
| 68 | 96,991 | 102,455 | 109,286 | — | — | — | — |
| 86 | 75,134 | 81,964 | 88,795 | 93,269 | 100,406 | 105,871 | 110,993 |
| 104 | 50,886 | 60,107 | 66,596 | 72,368 | 80,257 | 87,429 | 93,917 |
| 122 | 30,224 | 38,592 | 44,295 | 50,203 | 56,931 | 64,137 | 71,377 |
| 140 | 10,929 | 17,076 | 22,779 | 28,346 | 34,152 | 40,982 | 47,813 |
| 158 | — | — | 10,587 | 14,344 | 21,174 | 29,029 | 33,469 |

Table 14 – ACF60-00 HR - Heat capacity of the heat recovery unit for condition other than the nominal conditions; with output = 6.6 GPM.

| HEAT CAPACITY Btu/hr (Output = 8.8 GPM) | | | | | | | |
|---|-----------------------------|---------|---------|--------|--------|--------|--------|
| RECOVERY SYSTEM HOT WATER RETURN TEMPERATURE °F | EXTERNAL AIR TEMPERATURE °F | | | | | | |
| | 59 | 68 | 77 | 86 | 95 | 104 | 113 |
| 68 | 97,333 | 104,709 | 110,993 | — | — | — | — |
| 86 | 76,158 | 83,399 | 91,868 | 97,333 | — | — | — |
| 104 | 51,228 | 61,302 | 72,094 | 78,549 | 85,106 | 92,210 | 99,040 |
| 122 | 30,258 | 39,275 | 47,813 | 54,643 | 59,902 | 66,596 | 76,158 |
| 140 | 14,002 | 17,144 | 24,111 | 29,678 | 35,859 | 42,690 | 49,520 |
| 158 | — | — | 12,704 | 17,076 | 22,882 | 29,712 | 35,859 |

Table 15 – ACF60-00 HR - Heat capacity of the heat recovery unit for condition other than the nominal conditions; with output = 8.8 GPM.

| HEAT CAPACITY Btu/hr (Output = 11.0 GPM) | | | | | | | |
|---|-----------------------------|--------|---------|--------|--------|--------|---------|
| RECOVERY SYSTEM HOT WATER RETURN TEMPERATURE °F | EXTERNAL AIR TEMPERATURE °F | | | | | | |
| | 59 | 68 | 77 | 86 | 95 | 104 | 113 |
| 68 | 103,924 | — | — | — | — | — | — |
| 86 | 81,281 | 88,795 | 102,455 | — | — | — | — |
| 104 | 57,033 | 64,888 | 76,295 | 82,613 | 88,795 | 97,572 | 102,455 |
| 122 | 36,884 | 41,255 | 49,520 | 58,058 | 63,454 | 71,104 | 79,061 |
| 140 | 17,452 | 21,345 | 26,331 | 31,112 | 38,113 | 45,798 | 55,736 |
| 158 | — | — | 13,285 | 18,100 | 23,906 | 30,737 | 39,275 |

Table 16 – ACF60-00 HR - Heat capacity of the heat recovery unit for condition other than the nominal conditions; with output = 11.0 GPM.

**ACF60-00 HR
UNIT INTERNAL PRESSURE DROP OPERATION FOR AIR CONDITIONING ONLY (NO RECOVERY)**

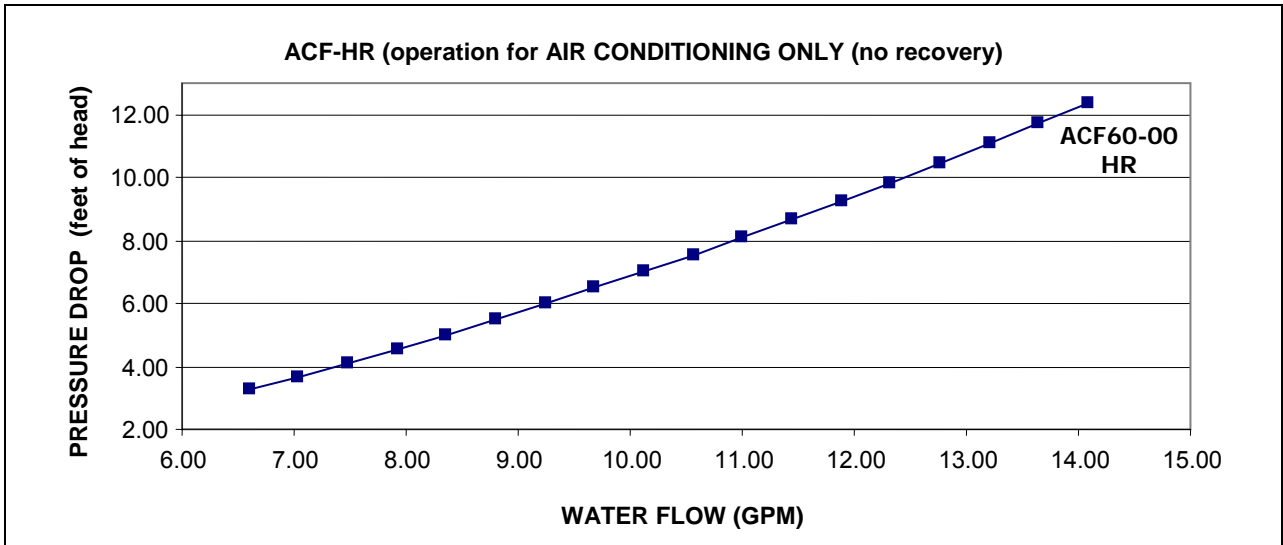

Graph 3- UNIT PRESSURE DROP AS A FUNCTION OF WATER FLOW, OUTLET WATER TEMPERATURE 44.6 °F

**ACF60-00 HR
HEAT RECOVERY UNIT INTERNAL PRESSURE DROP**

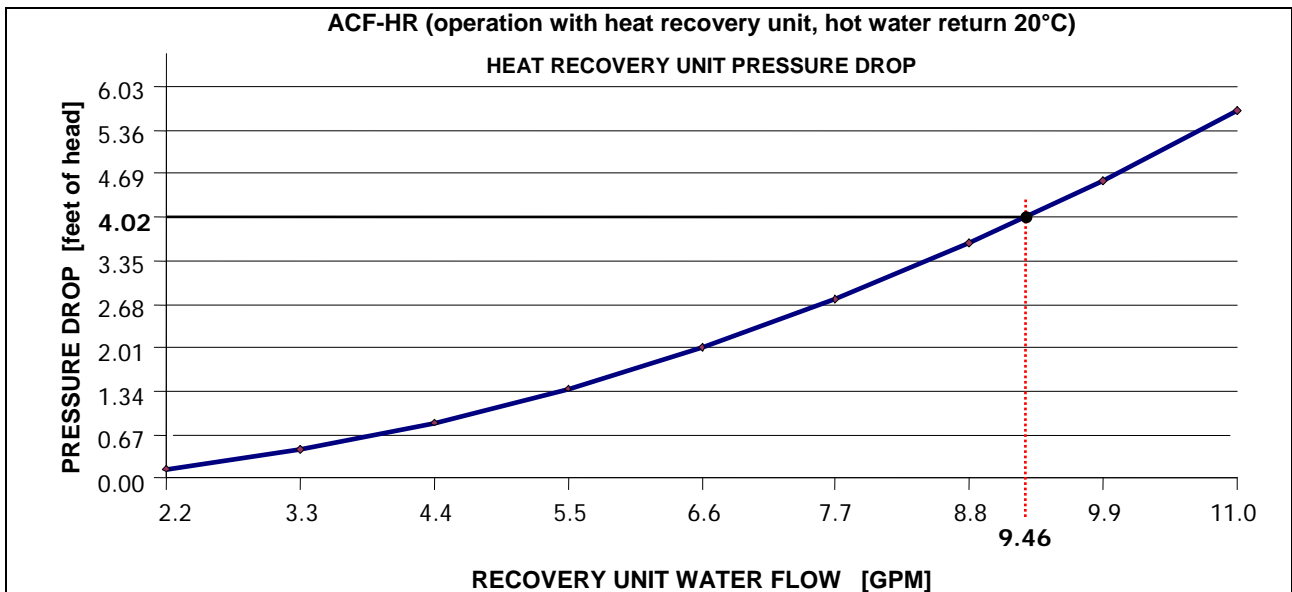

Graph 4 - ACF60-00 HR: Heat recovery unit pressure drop

2.4 DIMENSIONS

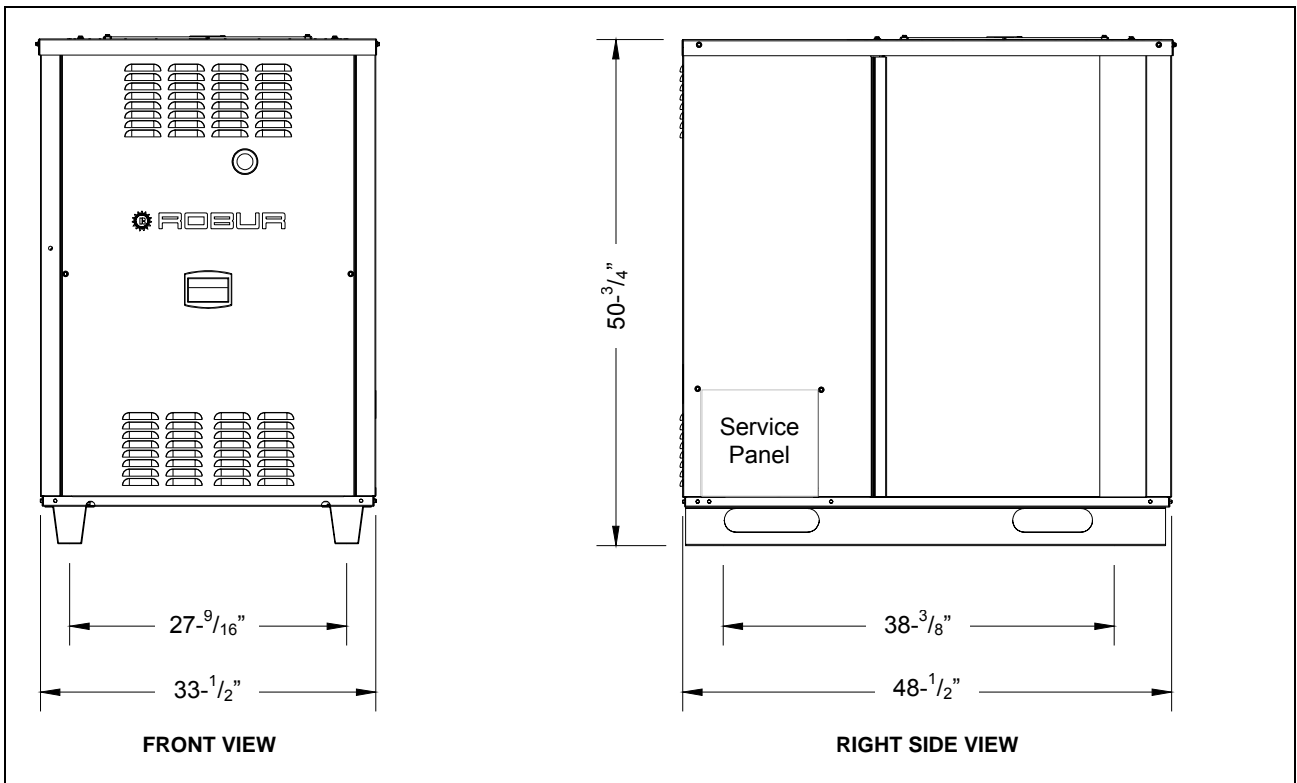

Figure 3 - ACF60-00, HT, TK, LB, HR DIMENSIONS.

3. INSTALLATION

3.1 GENERAL RULES

Only qualified technicians, in compliance with the manufacturer's instructions, should carry out the installation and maintenance of the ACF60-00 unit. The installation of the appliance must conform to the requirements of the authority having jurisdiction or in the absence of such requirements, to the latest edition of the **National Fuel Gas Code, ANSI Z223.1**. If the unit is installed in Canada, the installation must conform to the **Canadian Gas Association Standard CAN1 B149.1** and **.2**.

All wiring should be installed in accordance with the latest edition of the **National Electrical Codes, ANSI/NFPA No. 70, CSA Standard C22.1** when installed in Canada, and with any local codes.

The manufacturer cannot be held responsible for any damages to persons, animals or goods due to improper, erroneous or irrational installation of these appliances.

To ensure that a correct installation and maximum unit performances are obtained, the following rules have to be followed:

- Unpack the unit carefully, checking that it has not suffered damage during transport. Each unit is factory tested before shipping, if damage is found report this immediately to the haulage contractor.
- **Each unit must be installed outdoors in an area of free natural air circulation** and does not require particular weather protection.
In no case must the unit be installed in a room.
- No overhead obstructions should block the outlet of air from the unit top.
- **The unit should not be installed so that the fan discharge is in close proximity to the fresh air intakes of a building or in such a manner that hot or contaminated air from flues, dryer vents, chimney, etc., could be drawn into the unit by the condenser fan.**
- The front and rear sides of the unit must have a **minimum clearance of 31-1/2" inches and 24 inches, respectively, (for safety, maintenance and servicing) from any combustible surface, walls or other stationary constructions. The left and right sides require a minimum distance of 18 inches for proper airflow toward the condenser.**
- Be sure that gas supply provided from the gas main meets the manufacturer's specifications. Inlet gas pressure to the unit must not exceed 14.0" W.C. on natural gas or propane gas. The minimum Inlet gas pressure at the unit is 5.0" W.C. on natural gas and 11.0" W.C. on propane gas.

WARNING

The electrical safety of the unit is obtained only when it is correctly connected to an efficient grounding system, which meets existing applicable safety standards. Never use gas supply piping to ground the appliances. The ground wire should be longer than power supply wires for safety reasons. If the power supply wires are accidentally stretched, the ground wire will be the last to break. By following this rule, good ground continuity will be assured.

3.2 INSTALLATION OF THE UNIT

HANDLING OF THE UNIT ON SITE

When arriving at the installation site, visually inspect the unit for any signs of damage to the package, which may indicate possible unit damage.

Once on site, the units must remain in the factory packaging and only be unpacked at the moment before installation.

Before locating and unpacking the unit, make a hole in the package to check for ammonia odor. If ammonia odor is present, contact the factory.

LOCATION

The chillers **must be installed outdoors** in an area of free natural air circulation.

The installation inside a room or a building is not allowed.

There must be a minimum clearance of 4 feet horizontally from electric meters, gas meters, regulators, and relief equipment and in no case located above or below these items unless a 4 feet horizontal distance is maintained.

The unit can be installed at ground level, on a platform or on the roof (if it can withstand the weight).

The noise generated by the condenser fan during unit operation is not excessive. However, avoid locating the unit in an area adjacent to bedrooms or neighboring buildings (see Figure 4).

Also, avoid installing the unit in building corners, where air turbulence can take place or the unit noise (reverberation) can be amplified.

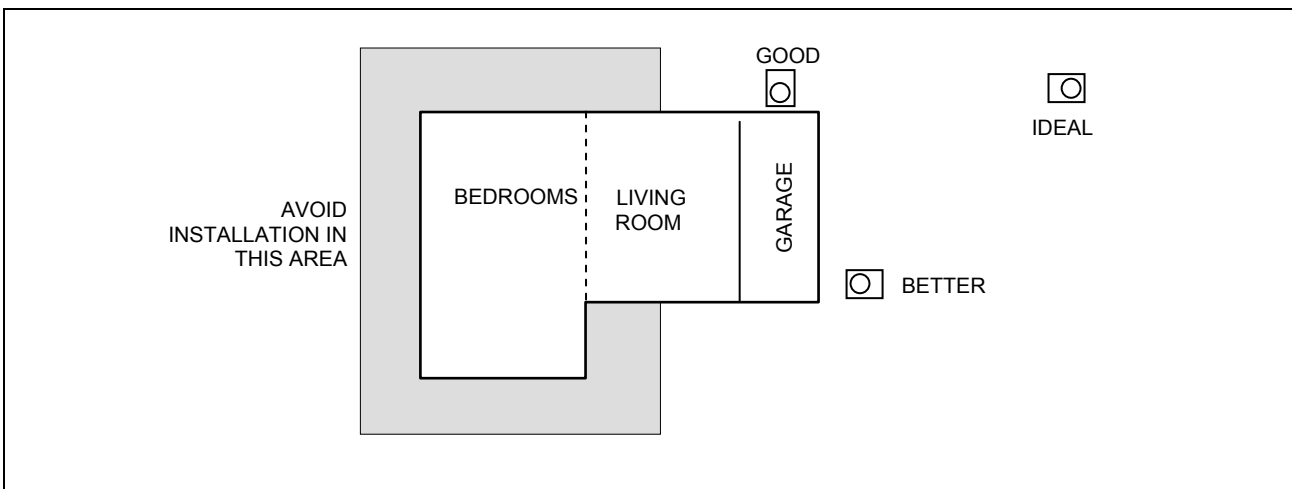

Figure 4 - LOCATION OF THE UNIT

CLEARANCES

A free space is to be provided around the unit to allow for proper unit operation and for servicing. The minimum clearance from walls, obstructions and other units should be as follows (see Figure 5):

- right / left side: 18 inches
- rear side: 24 inches
- front side: 31-¹/₂ inches

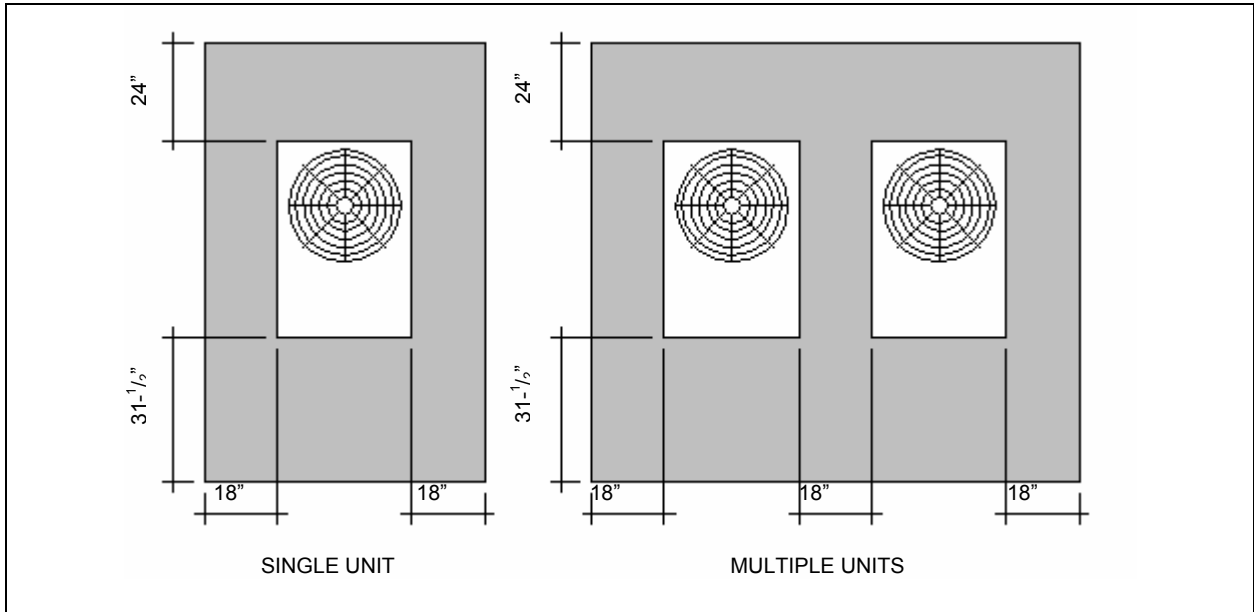

Figure 5 – CLEARANCES FOR CORRECT INSTALLATION OF THE UNIT

There **MUST NOT** be any obstructions or structural overhangs (roof edges, balconies) over the top of the unit. The re-circulation of the air discharged from the condenser results in a poor unit performance.

When the unit is installed in close proximity to buildings, keep the unit away from the roof edge drip line. In no case should the unit be placed within 6 feet of any external air intakes of the building. For installations on balconies or roofs, the unit should not be located within 8 feet from chimney flues, outlets and other such vents. It is important that the unit is located so that hot or contaminated air **IS NOT** drawn into the air intakes of the unit (see Figure 6).

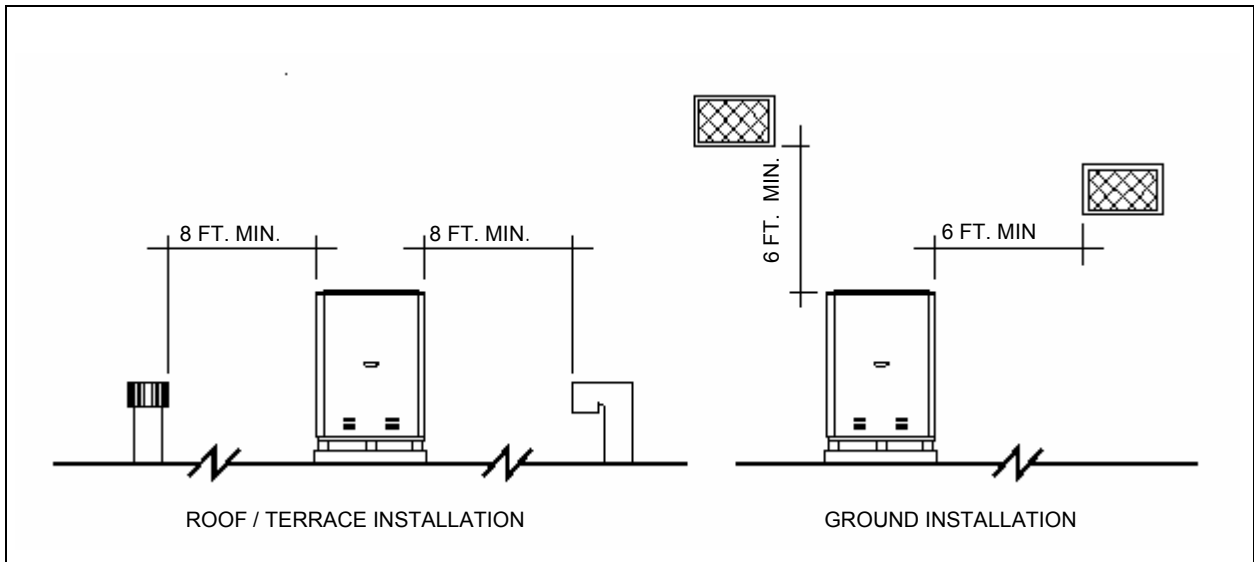

Figure 6 – CLEARANCES FROM VENT OUTLETS, CHIMNEY FLUES AND AIR INTAKE OPENINGS

GROUND INSTALLATION

Ground level units should be supported on a LEVEL concrete pad with a minimum thickness of 4" and slightly larger than the unit base (see Figure 7 for typical slab dimensions). Local soil conditions will actually dictate the slab thickness required to prevent shifting.

Do not allow the concrete slab touch the foundation of a structure. Unit operational noises can be transmitted inside the structure if they are connected.

Ground level installations should use vibration-damping base supports, available from the factory. Another option is to use 4" thick concrete blocks positioned under the unit, instead of the factory base supports.

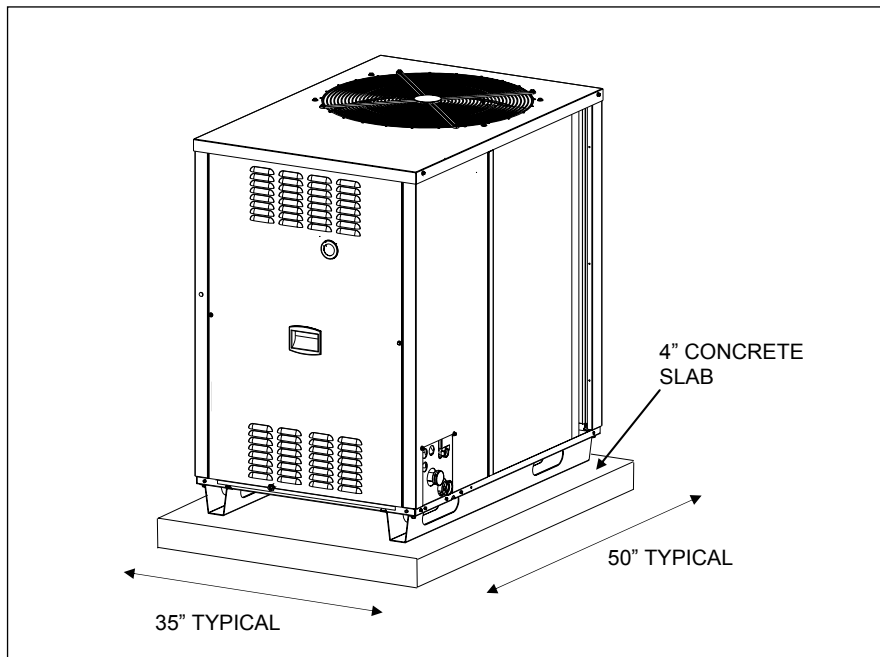

Figure 7 – DIMENSIONS OF THE UNIT BED

ROOF / TERRACE INSTALLATION

If the unit must be lifted by a hoist for installation, leave it on the crate base. Attach hoist lines to the crate base and use spreader bars to prevent the hoist lines from damaging UNIT cabinet panels.

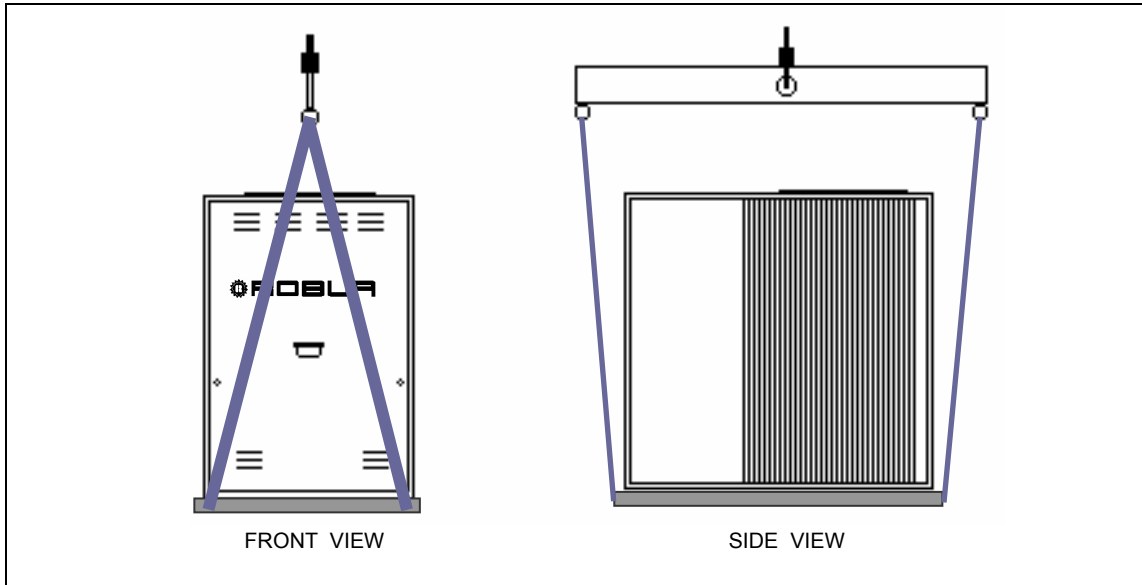

Figure 8 – HANDLING OF THE ACF60-00 UNIT

Although approved for installation on a combustible base, the unit must not be installed directly on the roof surface. Use base supports for the installation (see Figure 7).

Both the unit and the supporting base weight should be sufficiently supported by the roof joists.

Provide for a gangway all around the unit for maintenance purposes.

Installation on roofs directly above sleeping quarters should be avoided if possible. If not possible, special consideration must be given to the transmission characteristics of the building structure. The use of vibration isolators under the equipment (acoustically insulated bases) and approved flexible connections (vibration-damping pipe fittings) between the unit and the piping system is recommended.

LEVELING

The unit should be level both front to back and side to side. Place a level on the top of the unit to check for level. If the unit is not level, metal shims are recommended for use under proper corners to obtain level. If the shim(s) thickness exceeds 1/2", support shims should be inserted under the center of the unit.

4. HYDRONIC AND GAS INSTALLATION

4.1 WATER PIPING DESIGN AND INSTALLATION

Piping for the chiller is to be designed and installed as a closed hydronic circuit.

The following items (not supplied) must be installed close to the unit (see Figure 9):

- FLEXIBLE CONNECTIONS to avoid vibration transmission to the chiller water lines.
- MANOMETERS to measure Inlet and Outlet pressure.
- CHILLED WATER FILTER mounted in the water Inlet line to remove debris from the chiller water lines.
- WATER FLOW RATE VALVE for adjusting proper water flow rate.
- WATER PUMP properly sized for system.
- EXPANSION TANK must be properly sized based on the hydronic system size, maximum thermal expansion, and maximum water pressure.
- FILL VALVE for filling, draining or flushing the hydronic system.
- AIR BLEED set at the highest point in the hydronic system for removal of air.

WARNING

To ensure the correct operation of the unit and to avoid the water freezing, add 10% by volume of mono-ethylene glycol (antifreeze) to the circulation water. Add more mono-ethylene glycol as needed for the minimum external temperature of the installation zone (see Table 18, page 55).

When using an automatic water charge system, the mono-ethylene glycol percentage must be checked once a year.

There must be correct chilled water flow when the unit is operating and during the shut down period (600 seconds, between turning the burner off and complete shutdown of the appliance).

Piping (diameters of tubes etc.) must be sized appropriately in order to ensure the correct chilled water flow necessary for the proper operation of the unit. The water lines should also be sized so the maximum velocity of the water/mono-ethylene glycol solution in the lines does not exceed 6 feet per second to avoid excessive noise.

Absorption cooling unit does not require obligatory installation of cold-water storages (because there is no compressor in the system).

The use of the cold-water storage is anyhow suggested, in order to absorb frequent variations of thermal load, that reduces the working time of the unit, reduces the energy consumption and consequently saving money. It is recommended specially when water quantity in the system is lower than 18.5 gallons for each installed ACF60-00 unit.

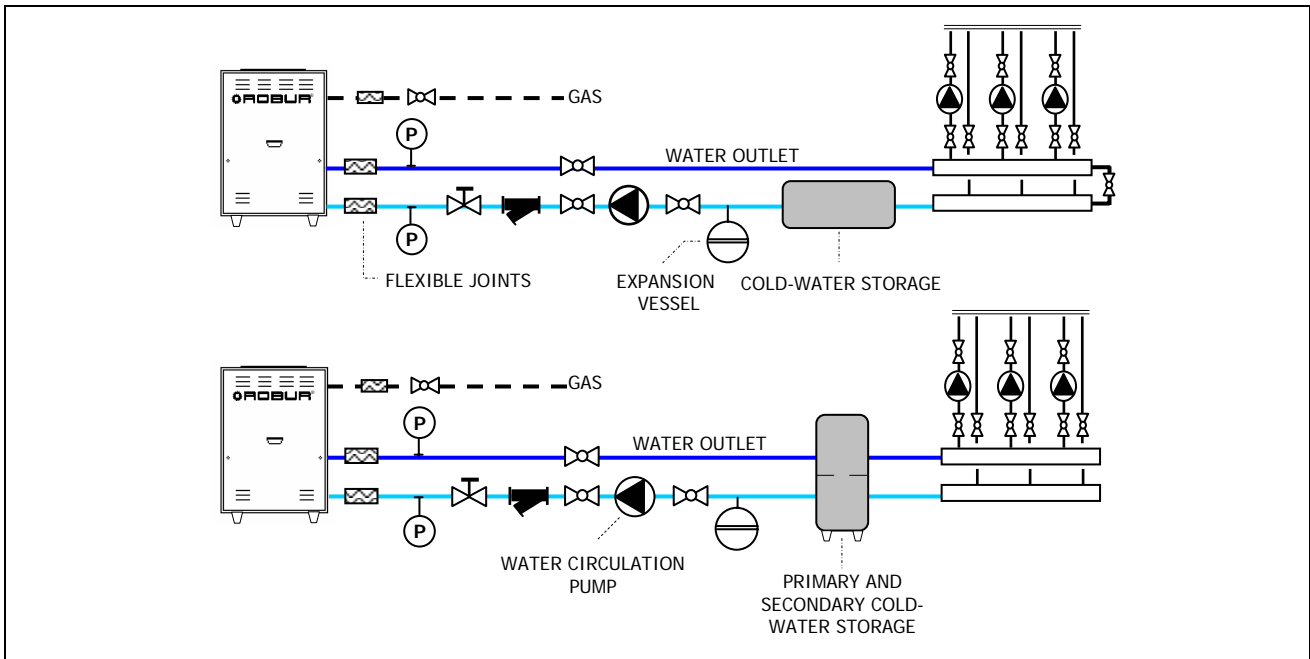

Figure 9 – EXAMPLE OF HYDRONIC SYSTEMS WITH SINGLE COLD-WATER STORAGE (TOP) and PRIMARY-SECONDARY WATER STORAGE (BOTTOM)

When rigid pipes are used, it is recommended to use flexible connections between the unit and piping to avoid vibration transmission.

All piping must be properly insulated according to federal and local codes to avoid thermal losses and condensate on the water lines. All seams and joints should be carefully made so as to be air and watertight.

For size of water connections on the unit, refer to TECHNICAL DATA sheet (2.3)

Connections at the coil or heat exchanger must be performed in accordance with the recommendations of the coil or heat exchanger manufacturer. For best performance, the supply-chilled water line must attach to the side of the coil or heat exchanger nearest the exit of the leaving cooled medium.

If the heat exchanger is an air coil, the air coil must be installed downstream from the furnace to avoid condensation in the furnace. Additionally if the heat exchanger is an air coil, a “P” trap must be provided to drain condensate. The height of the “P” trap must be sufficient to ensure drainage of condensate. Any horizontal run of the condensate drain line must slope $\frac{1}{4}$ ” for each running foot and not be smaller than $\frac{3}{4}$ ” I.P.S. to assure the condensate will drain by gravity. The condensate drain line must be insulated and ran to a suitable drain.

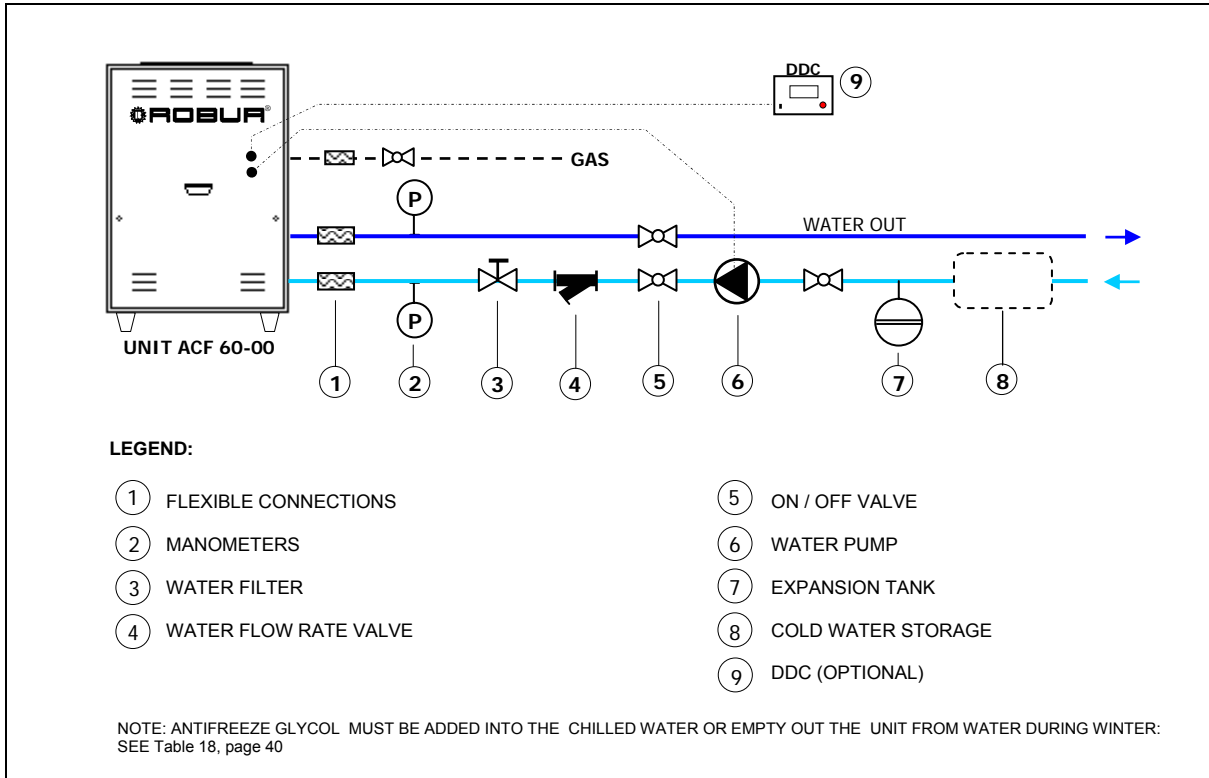

Figure 10 – WATER PIPING DIAGRAM FOR A SINGLE ACF UNIT

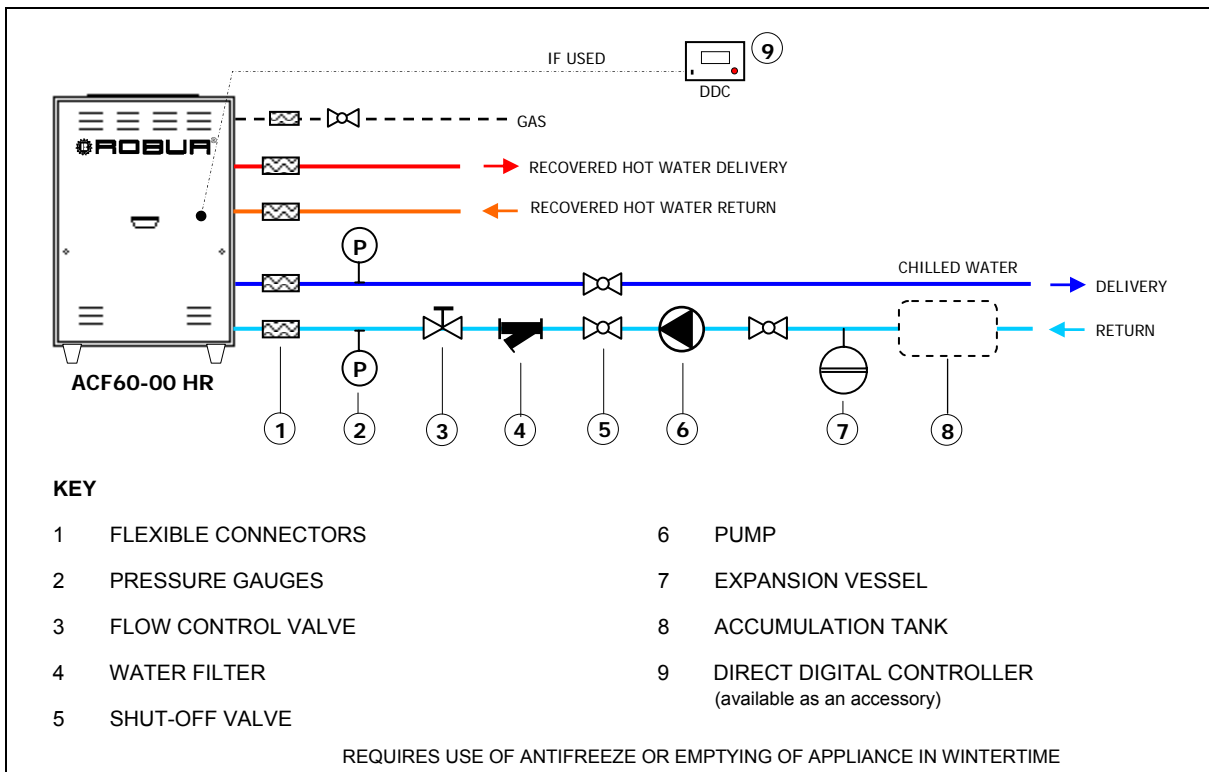

Figure 11 – WATER PIPING DIAGRAM FOR A SINGLE ACF-HR UNIT

The connections for water and gas piping are located at the service plate on the right-side of the chiller (see Figure 3).

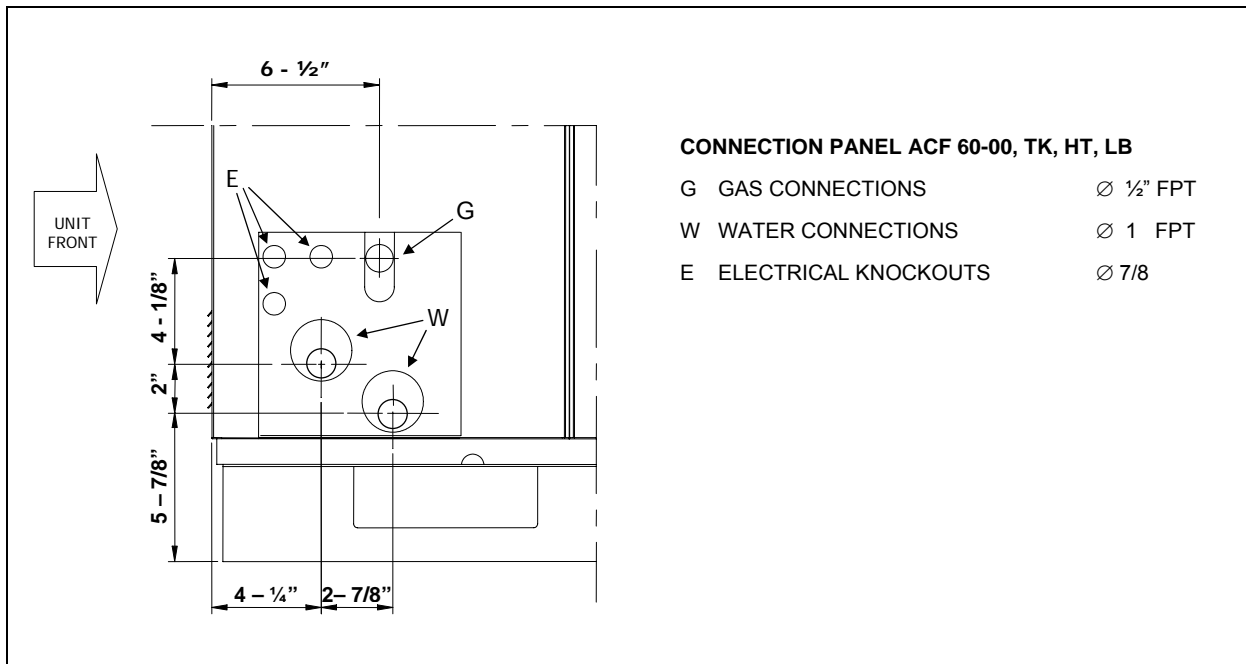

Figure 12 – ACF 60-00, TK, HT, LB - SERVICE PLATE DIMENSIONS

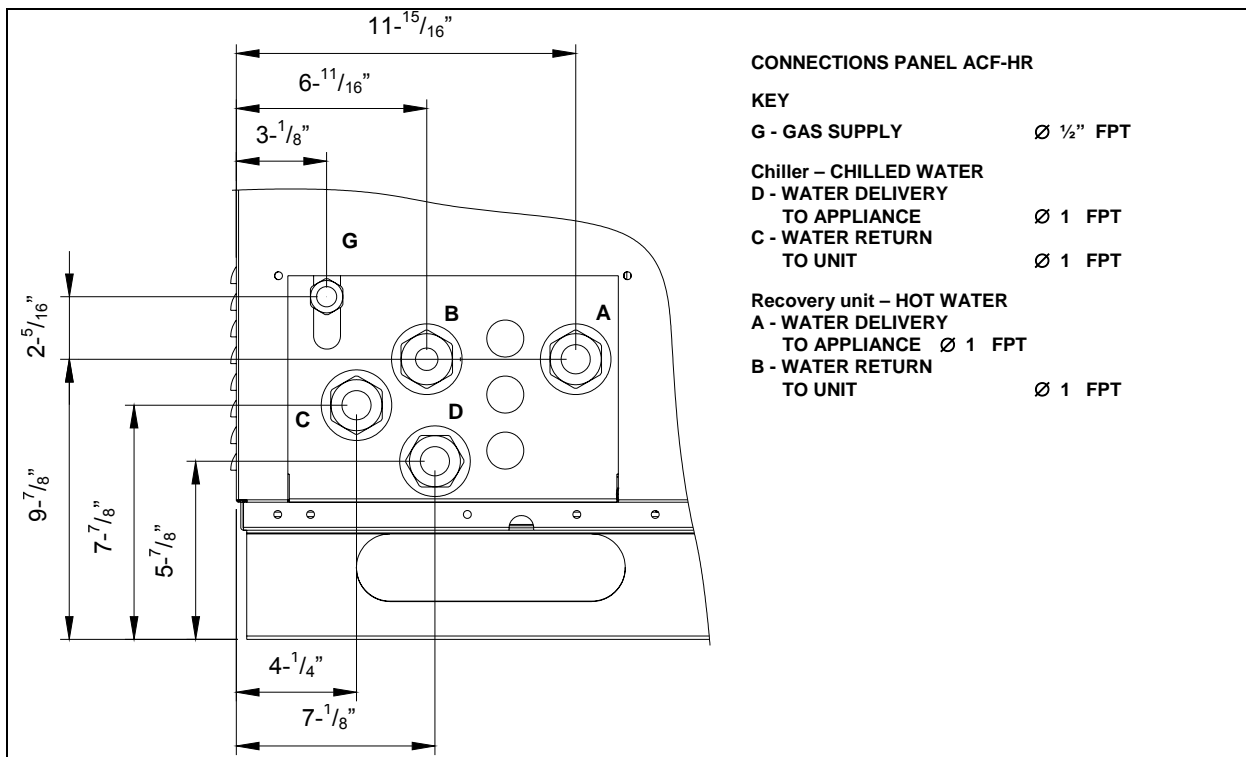

Figure 13 – ACF 60-00 HR - SERVICE PLATE DIMENSIONS

4.2 GAS SUPPLY PIPING

All gas piping must conform to the latest edition of **National Fuel Gas Code ANSI Z223.1** and all local gas piping codes. In Canada, the gas piping must conform to the **CGA Standard CAN1 B149.1** and **.2, "Installation Code for Gas Burning Appliances & Equipment"** and local codes. Your gas utility must be contacted regarding local requirements, type and size of gas lines. Safe lighting and other performance criteria were met with the gas manifold and control assembly provided on the chiller, when it underwent the tests specified in the standards shown on the rating plate.

For Natural Gas the minimum Inlet gas pressure to the chiller is 5" W.C. and the maximum is 14" W.C. For Propane Gas the minimum Inlet gas pressure to the chiller is 11" W.C. and the maximum is 14" W.C.

For size of gas connection to the unit, see Figure 12.

WARNING

Gas supply pressures higher than those stated above could damage the gas valve, resulting in a fire hazard.

Vertical gas piping must be trapped and a means provided to drain condensate that may accumulate in the piping during the cold season. Insulation may also be necessary for the gas piping to prevent excessive accumulations of condensate.

An approved union should be installed in the gas line near the unit and down stream of any external shut-off valve that may be required by local codes.

Be sure to use materials resistant to the LPG corrosive action when making pipe connections. Use an approved sealing compound resistant to propane gas on all male pipe threads.

The chiller and its gas connections must be leaked tested before placing the chiller in operation.

The chiller and its individual shut-off valve must be disconnected from the gas supply piping system during any pressure testing of the gas piping system at test pressures **in excess of 1/2 PSig.**

The chiller must be isolated from the gas supply piping system by closing its individual shut-off valve during any pressure testing of the gas piping system at test pressures **equal to or less than 1/2 PSig.**

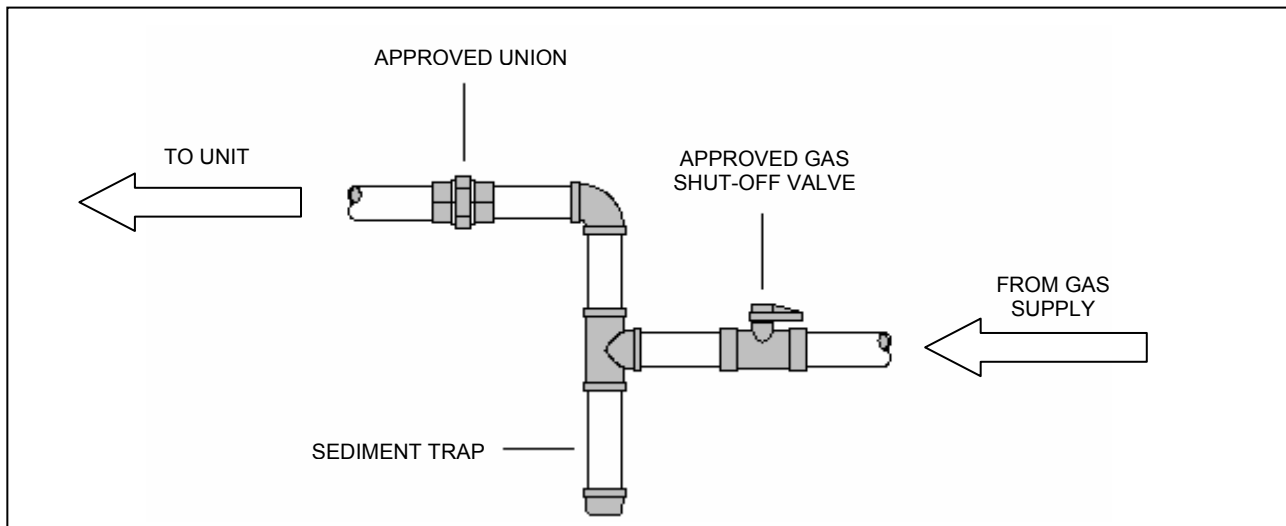

Figure 14 – TYPICAL GAS CONNECTION

5. ELECTRICAL CONNECTION

5.1 POWER SUPPLY AND PUMP WIRING FOR A SINGLE ACF60-00 UNIT

All wiring should be installed in accordance with the latest edition of the **National Electrical Codes, ANSI/NFPA No. 70, CSA Standard C22.1** when installed in Canada, and with any local codes.

The UNIT electrical system is wired for single-phase, 208-230 volt and 60Hz operation. The electrical control box includes a 208 – 230 - 24 volt transformer to supply low voltage to the control system. The high voltage line connections to be made at the time of installation consists of connecting 208-230 volt, 60 Hz to the high voltage terminal board of the control panel. A fused disconnect switch should be installed in the 208-230 volt supply line within sight of and not over 50 feet from the unit.

NOTE

- An error in wiring installation could cause problems during the UNIT operation and could damage the electrical components of the appliance.
- The unit must be electrically grounded in accordance with national requirements.
- The power supply line must not be used to turn the unit "ON" or "OFF". The dedicated control switch in the R-Y line is for this purpose.
- Disconnect the power supply lines only when assured that unit is completely shut off.

WARNING

DO NOT OPERATE the unit unless the chilled water system is filled with water and antifreeze.

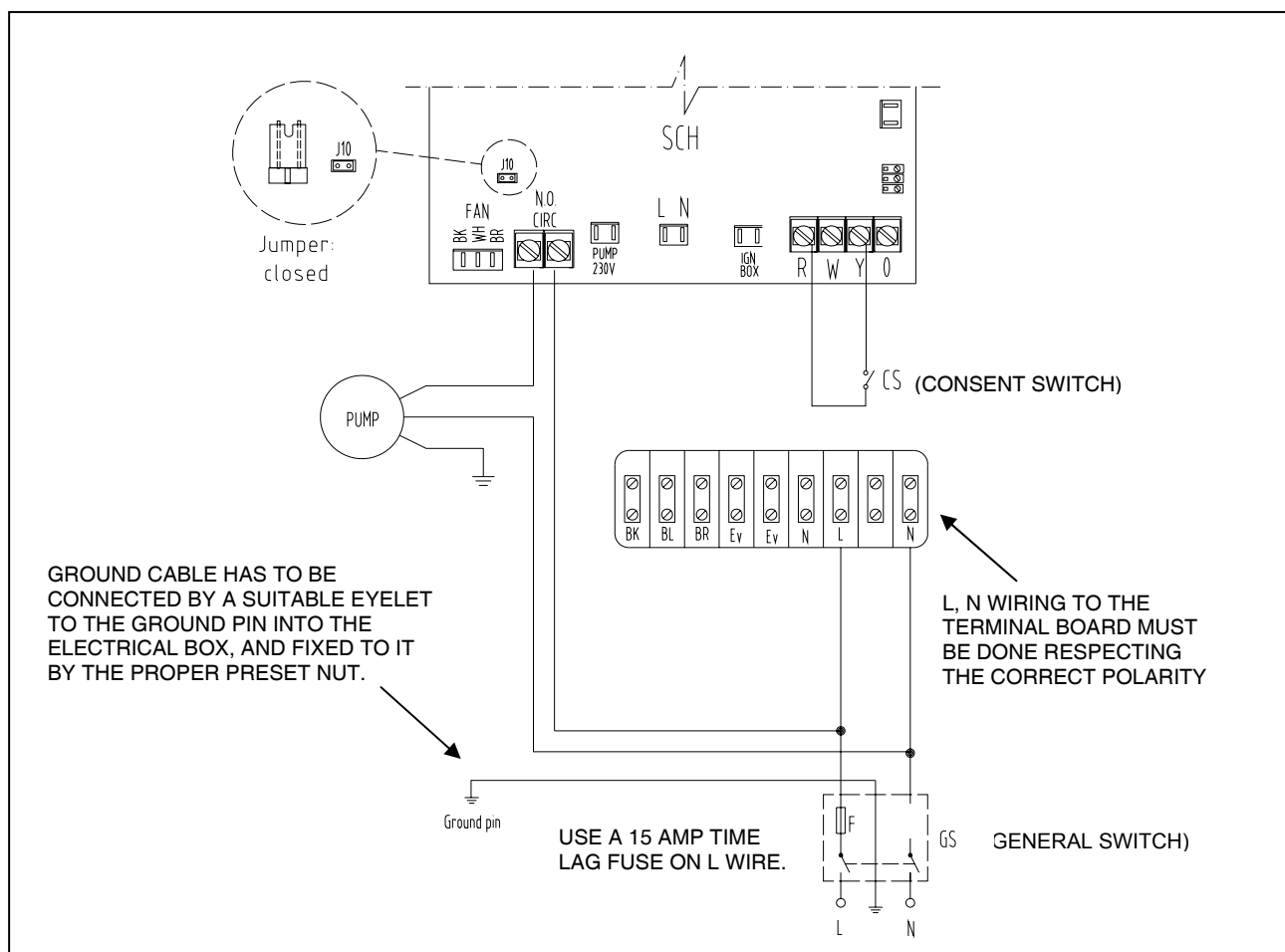

Figure 15 – WIRING FOR A SINGLE ACF60-00 UNIT WITH PUMP ABSORBED CURRENT LESS THAN 4 AMP.

WARNING

If power for the water pump is taken from the high voltage terminal block located in the electrical control box, as shown in Figure 15, the minimum circuit ampacity for the unit must be increased above that listed in the TECHNICAL DATA sheet in SECTION 2 to accommodate the additional current draw of the water pump installed. **The maximum current carrying capacity of the N.O. Contact is 4A.** If the current is above 4A, use an additional relay controlled by N.O. Contact on the S61 board.

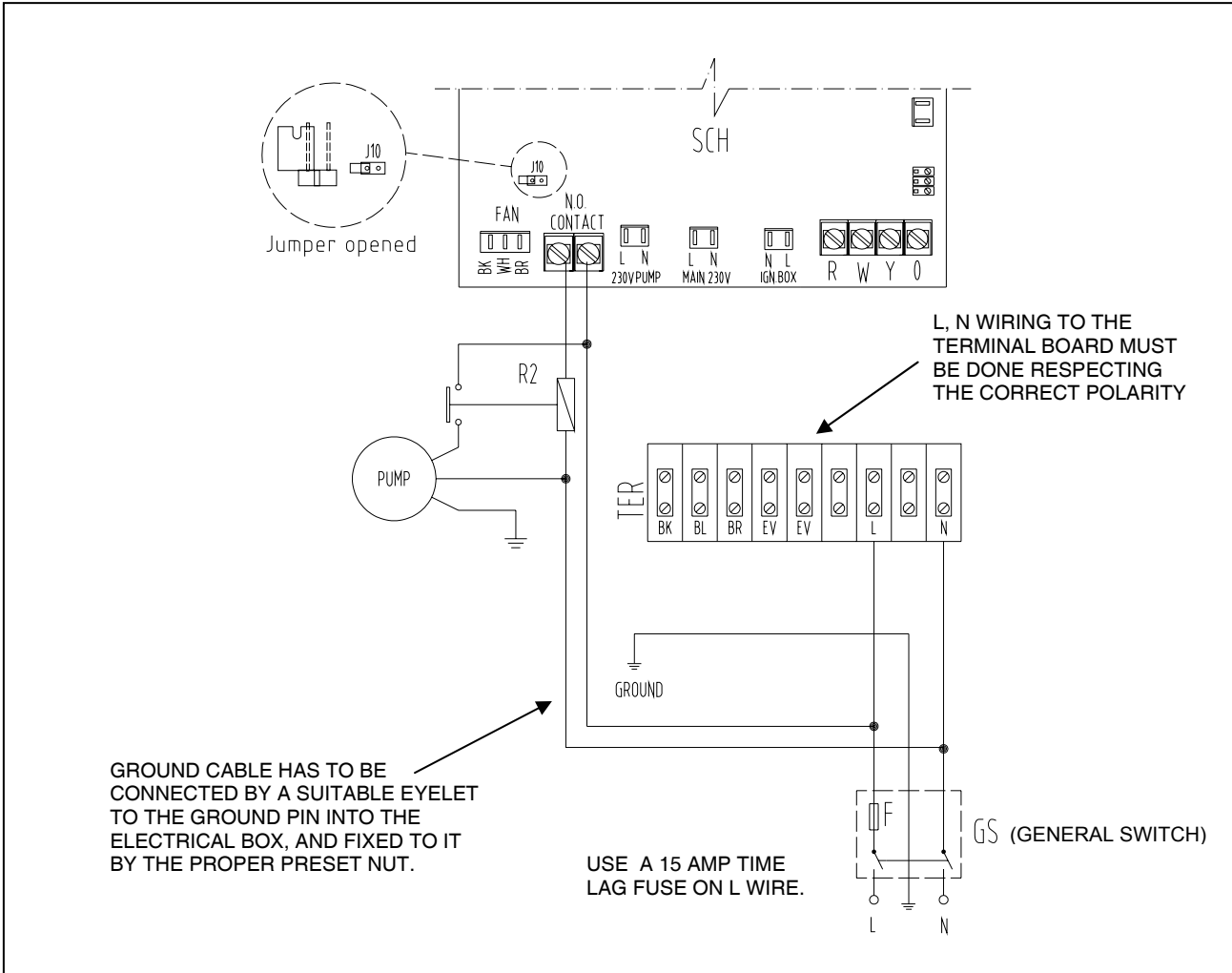

Figure 16 – WIRING FOR A SINGLE ACF60-00 UNIT WITH PUMP ABSORBED CURRENT MORE THAN 4 AMP

5.2 POWER SUPPLY AND PUMP WIRING FOR 2 OR MORE ACF60-00 UNITS

The figure shows typical wiring for 2 or more ACF60-00 units. The transformer is required to feed N.O. contacts with low voltage current; this is done for safety reasons: when doing maintenance and a unit is shut off, these contracts could still remain fed. In this case, no matter if pump current absorption is more or less than 4 amp.

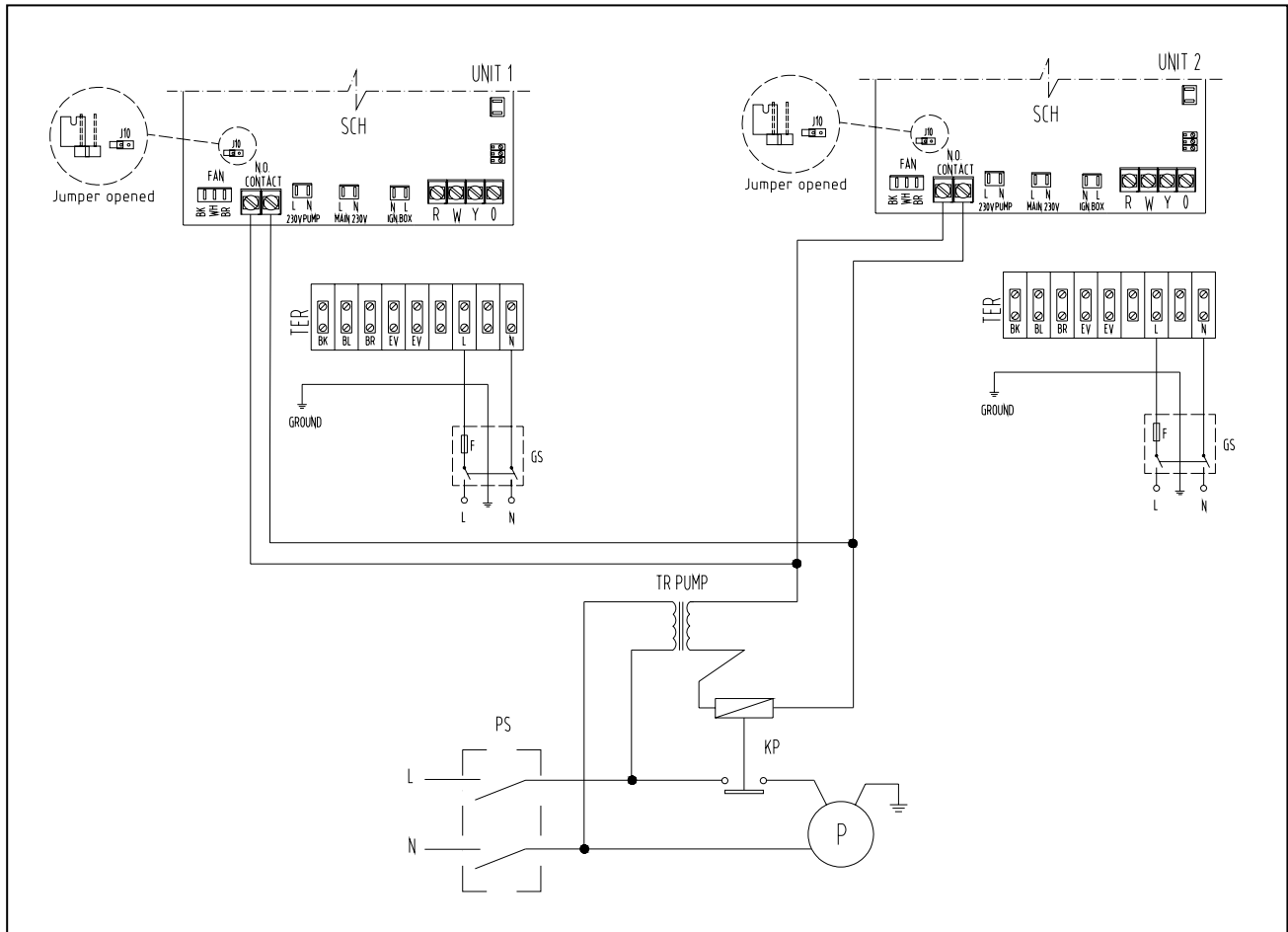

Figure 17 - WIRING FOR 2 ACF60-00 UNITS WITH LOW VOLTAGE TRANSFORMER

5.3 CONTROL SWITCH WIRING AND THERMOSTAT LOCATION

CONSENT SWITCH WIRING

If DDC is not used, a consent switch that provides an ON/OFF function is to be connected to the R and Y on the S61 board. This wiring will carry 24-volt current and it is recommended to use a cable with the correct number of color-coded 18 AWG wires.

An isolation relay MUST be used to separate the chiller's transformer from any additional equipment having a transformer or damage to the S61 board will occur. Isolation relays must have a 24-volt AC coil, which does not present more than 0.25 amp load to the control circuit.

THERMOSTAT LOCATION

If the control switch is a thermostat, the thermostat should be located on an inside wall about 54 inches above the floor. It should be located so that it will not be affected by any of the following items:

- Discharge air from a supply grille
- Drafts
- Direct sunlight through a window or glass door
- Electrical Appliances such as television, radio or lamps.

The thermostat should be located so that it senses the average temperature of the conditioned space. The thermostat should be mounted according to the manufacturer's instructions (packaged with the thermostat).

THERMOSTATS USING A MERCURY BULB SWITCH MUST BE LEVEL. If the thermostat has a built-in heating anticipator, this must be set as required by the heating unit load.

5.4 ACF60-00 WIRING

If any of the original wire as supplied with the unit must be replaced, it must be replaced with thermoplastic 221°F wire, except ground, high temperature and pressure switch wires 392°F or equivalent.

Igniter and flame sensor wire have to be replaced with Robur spare parts. See, SPARE PARTS, page 63.

Label all wires prior to disconnection when servicing the controls. Wiring errors can cause improper and dangerous operation.

In Figure 20, below, Thermostat THL (Hot water outlet thermostat) is placed only on ACF60-00 HR.

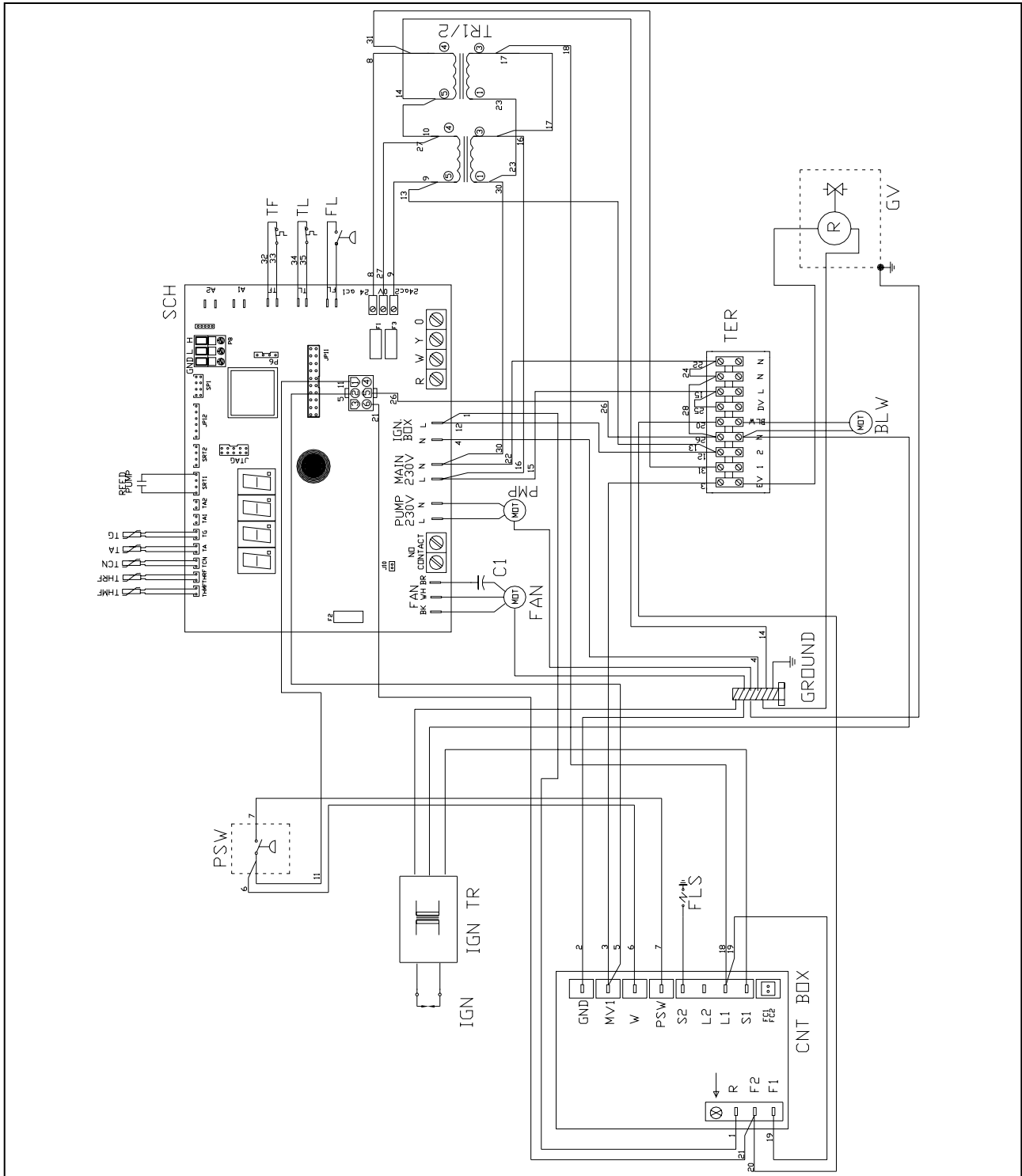

Figure 18 – WIRING DIAGRAM FOR ACF60-00

5.5 DDC CONNECTION

Connection with ACF60-00 UNIT

WARNING

For the connection of DDC (available as accessory) with ACF60-00 units, consult the instructions, figures and diagrams only contained in this subparagraph. For further details and/or information refer to the specific “DDC installation, programming and use manual”.

To well manage one or more units connected to the same hydronic system, it is important to use the DDC, available as accessory. In such a case, it is necessary to:

- Connect the DDC to the power supply (see “DDC: Electric supply wire connection”)
- Use a CAN-BUS wire to connect the units and the DDC (see “Connection of DDC to the unit”)

DDC: Electric supply wire connection

The DDC should be electrically supplied through a safety transformer 230 /24 V.a.c. – 60 Hz. With minimum power equal to 20 VA.

Use an electric supply wire (min. 2 x 18 AWG) and the 4 terminals connector of the DDC (placed at bottom left, back side) to make the connection as in Figure 19, respecting the following polarity:

- terminal 1 = 24 V;
- terminal 2 = 0 V;
- terminal 3 = ground

Warning: in all cases terminal 3 of the DDC terminals connector should be connected to one safety ground ($\leq 0,1\Omega$).

The DDC is also equipped with a plug battery which, in case of black out, stores in its memory the programmed values; **the plug battery lasts approximately 7 years**, then it should be changed by **Authorized Service Engineer**.

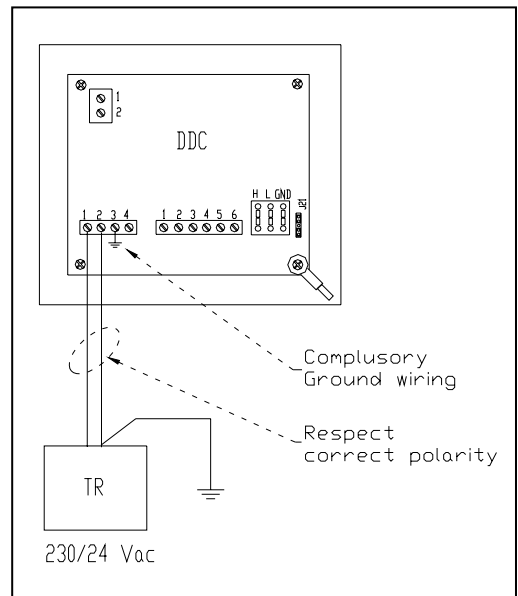

Figure 19– ELECTRICAL SUPPLY WIRE CONNECTION

Connection of DDC to the unit

The connection between DDC and the unit (or more units) is made through a CAN-BUS wire, in a way to create a parameters communication network, characterized by one series of “n” nodes (see Figure 20 and Figure 21, pag. 45). The parameters communication network can connect max 3 DDC.

NOTE

Every single object (ACF60-00 unit or DDC) at its connection to the communication network is intended to be a *node*. Every network is composed by 2 *terminal nodes* and of a certain number of *intermediate nodes*.

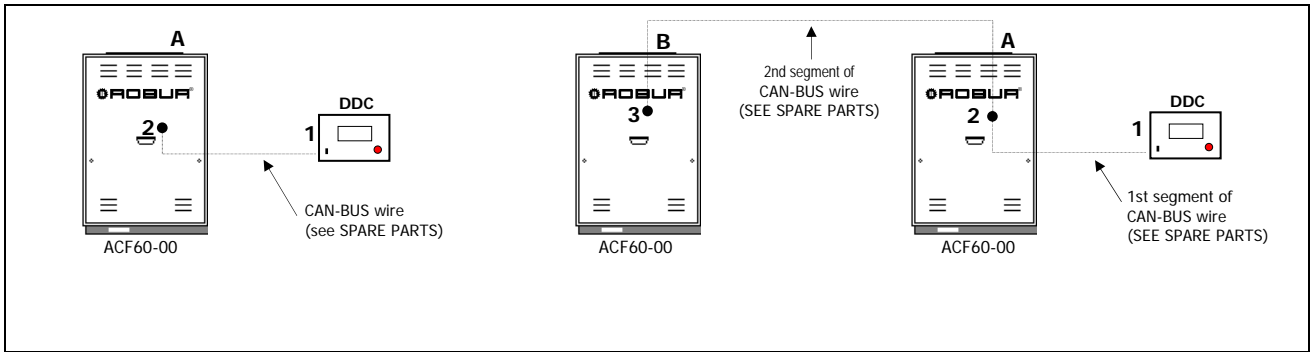

Figure 20 – EXAMPLE CONNECTION OF DDC TO SINGLE ACF60-00 UNIT (2 nodes network) AND TO N.2 ACF60-00 UNITS CONNECTED ON THE SAME HYDRONIC SYSTEM (3 nodes network).

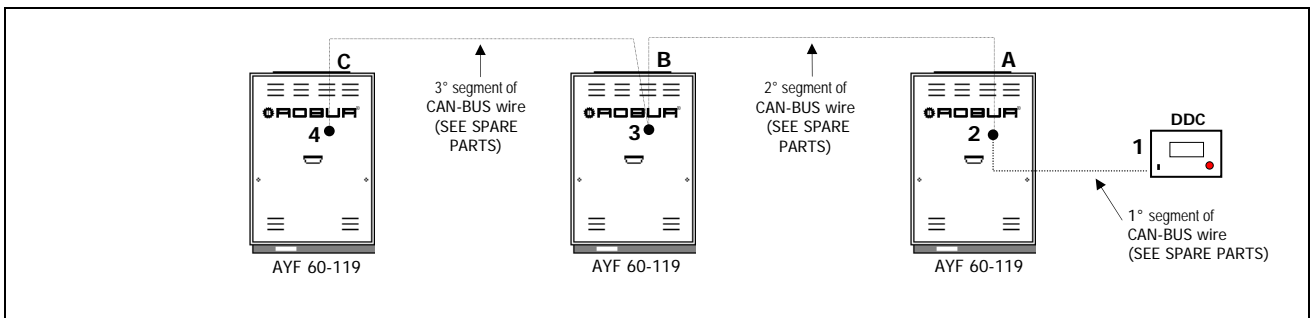

Figure 21 – EXAMPLE CONNECTION OF DDC TO N.3 ACF60-00 UNITS CONNECTED ON THE SAME HYDRONIC SYSTEM (4 nodes network).

CAN-BUS wire connection

If the network connection is max 650 ft cable long and has max 6 nodes (e.g.: 5 ACF60-00 + 1 DDC) a simple shielded wire 3 x 18 AWG is required.

For major lengths, the CAN-BUS wire should be compatible with **Standards Honeywell SDS**.

The next Table shows some examples of these wires, according to the total length of the wire itself:

| CABLE TYPE AND MODEL | COLOR AND SIGNAL | | | MAX DISTANCE COVERED ft |
|----------------------------|------------------|-----------|-------------|----------------------------|
| | BLACK = H | WHITE = L | BROWN = GND | |
| ROBUR NETBUS | BLACK = H | WHITE = L | BROWN = GND | 1475 |
| Honeywell SDS 1620 | | | | |
| BELDEN 3086A | BLACK = H | WHITE = L | BROWN = GND | 1475 |
| TURCK type 530 | | | | |
| DeviceNet Mid Cable | | | | |
| TURCK type 5711 | BLUE = H | WHITE = L | BLACK = GND | 1475 |
| Honeywell SDS 2022 | | | | |
| TURCK type 531 | BLACK = H | WHITE = L | BROWN = GND | 656 |

Table 17 – EXAMPLE OF TYPES OF WIRES USED FOR CAN-BUS

NOTE: “GND” is the common signal wire, and NOT a ground connection.

Take the CAN-BUS wire of suitable length for the connection between DDC and the unit and, for every network or CAN-BUS wire segments (from a node to another) cut sheath of the wire from both terminal for about 3” length and connect them to the proper nodes, on the electronic control board (S61) or on DDC.

- CAN-BUS wire connection to Electronic Control board

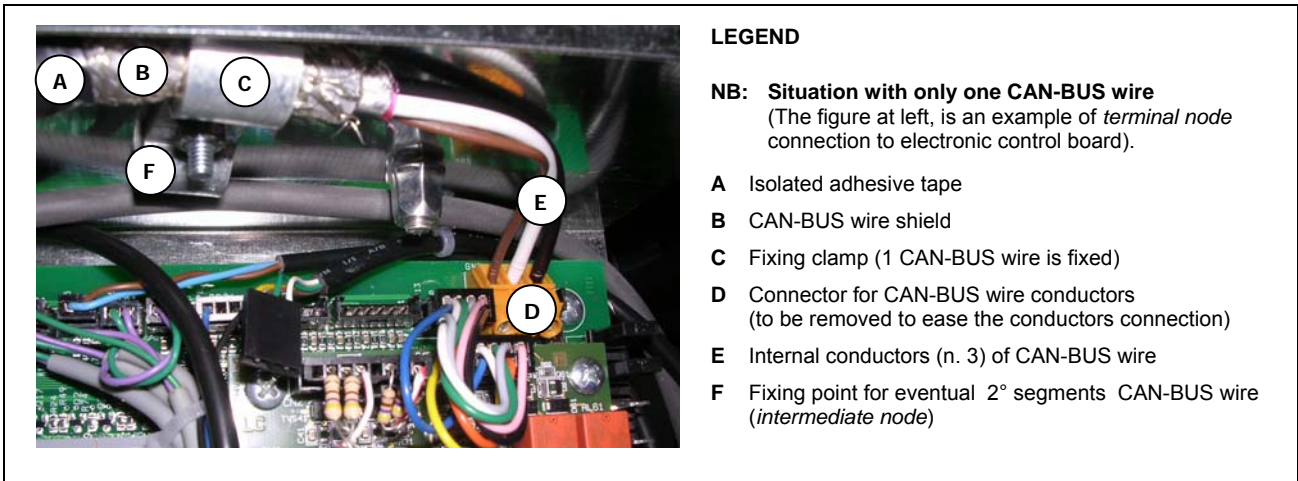

Figure 22 – EXAMPLE OF CAN-BUS CONNECTION TO ELECTRONIC CONTROL BOARD (EXAMPLE WITH ONLY ONE CAN-BUS WIRE)

1. Turn over the whole CAN-BUS shield (the aluminum part and the metal braiding) of the cut sheath part and fix it to the clamp (details B and C, Figure 22)

WARNING

Isolate the whole shielded part of CAN-BUS wire after fixing clamp to avoid any contact between the shield and the electronic control board (Particular A, Figure 22).

2. Extract from the electronic control board the orange color connector from its CAN Port (placed in right top angle of ECB: particular D Figure 22) and proceed with the following instructions of point 3.
3. If one INTERMEDIATE node of PARAMETERS COMMUNICATION NETWORK is under connection, follow all the next instructions (points **3a**, **3b**, **3c**, **4** and **5**); but if one TERMINAL node of PARAMETERS COMMUNICATION NETWORK is under connection, follow the instruction of points **3a**, **4** and **5** only.
 - 3a** Connect 3 conductors of CAN-BUS wire (particular E, Figure 22) respecting the signal/color indications as in Table 17, page 45 with 3 inlets H, L, GND of the same connector as in Figure 22 (see also details of Figure 23, page 47).
 - 3b** Repeat the same procedure of point 1 when connecting the 2nd CAN-BUS wire segment by fixing the 2nd wire to the same clamp (particular F, Figure 22).
 - 3c** Connect 3 conductors of the 2nd CAN-BUS wire, respecting the signal/color indications as in Table 17, page 45 with the other 3 inlets H, L, GND of the other connector as in Figure 24, pag 47.
4. Engage the connector to the electronic control board.
5. Adjust the Jumpers according to the following cases:
 - 1st CASE: on the orange connector of CAN port, there are three conductors (terminal nodes): in this case, the 2 jumpers existing beside the orange connector of CAN Port should be adjusted as indicated in Figure 23, page 47 (detail J1).
 - 2nd CASE: on the orange connector of CAN Port, there are 6 conductors (terminal nodes): in this case, the 2 Jumpers existing beside the orange connector of CAN Port should be adjusted as indicated in Figure 24, page 47 (details J1).

The Jumpers are pre-adjusted (in the factory) as in 1st CASE, that is closed.

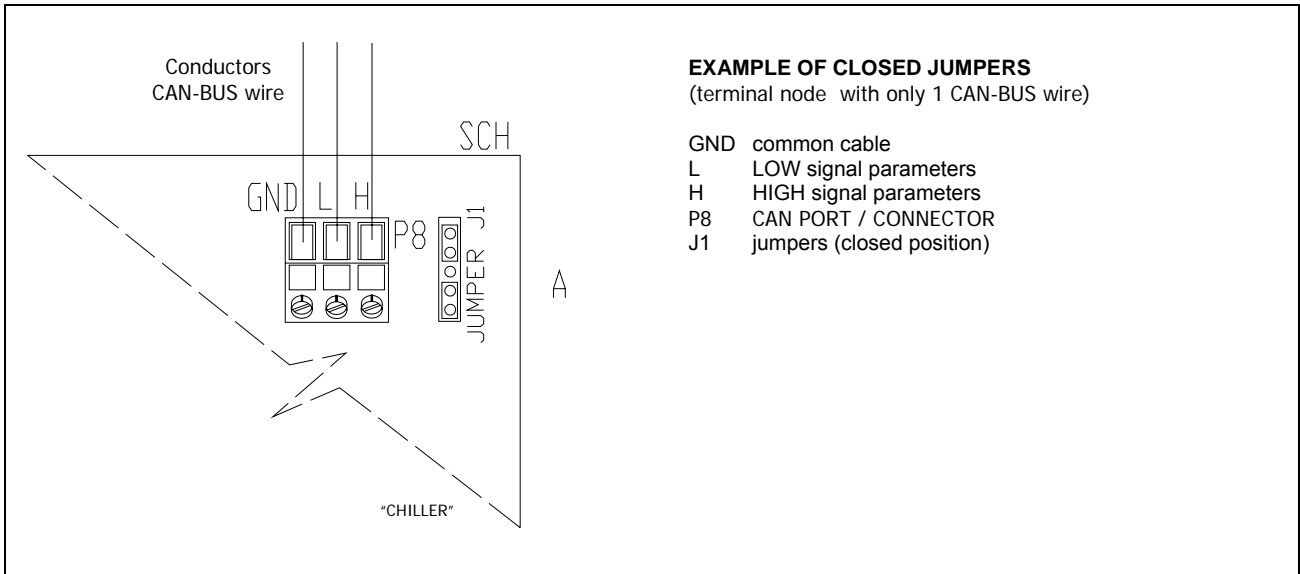

Figure 23 – DETAILED EXAMPLE OF THE CONNECTION OF ONLY ONE CAN-BUS WIRE WITH THE ELECTRONIC CONTROL BOARD

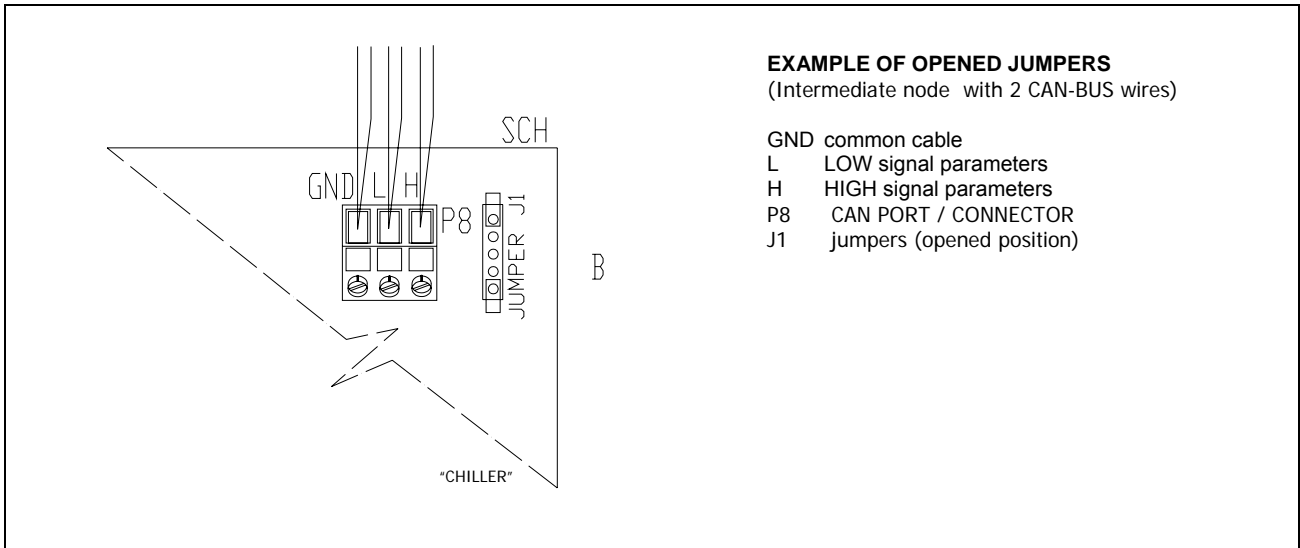

Figure 24– DETAILED EXAMPLE OF THE CONNECTION OF TWO CAN-BUS WIRES WITH THE ELECTRONIC CONTROL BOARD

- CAN-BUS wire connection to Digital Display Control (DDC)**

WARNING

Like the orange connector of the electronic control board, the DDC connector, too, has two different situations of connection (see Figure 26, Figure 27 page 49). The Jumpers (J21) are closed in the factory as in 1st CASE.

1. Take from the supplied bag the orange connector of CAN Port.
2. Connect 3 conductors of CAN-BUS wire (Particular B, Figure 25) respecting the signal/color indications as in Table 17, page 45 with three inlets H, L, GND of the connector as in Figure 25; see also Figure 26, page 49.
3. **If one intermediate node** of parameters communication network is under connection, follow the instructions of points **3a, 3b, 3c, 3d**; but **if one terminal node** of parameters communication network is under connection, go directly to point **4**.
 - 3a Connect 3 internal conductors of the other segment of CAN-BUS wire (after cutting the sheath from terminals) with 3 inlets H, L, GND of the DDC connector as in Figure 27, page 49.
 - 3b Remove the back cover of the DDC unscrewing the 4 fixing screws.
 - 3c In the electronic control board of DDC, ad just the Jumpers (J21) placed beside the orange connector of CAN Port (P8) as in Figure 27, page 49.
 - 3d Fix the back cover of the DDC using 4 screws
4. Engage – from the back cover hole of DDC – the orange connector of CAN Port to the DDC electronic control board.
- 5a Roll up the cut shield of the above mentioned CAN-BUS wire and connect it with an eyelet terminal of 0.16” (particular C&D, Figure 25).
- 5b (only for intermediate node) roll up the cut shield of the other CAN-BUS wire and connect it with eyelet terminal of 0.16” (particular C&D, Figure 25).
6. Unscrew the right bottom screw of the DDC back cover (particular D, Figure 25) and inset it to the eyelet terminal (s) and screw it down again.
- 7 Isolate – with suitable adhesive tape – the shield part of the wire (particular A, Figure 25).

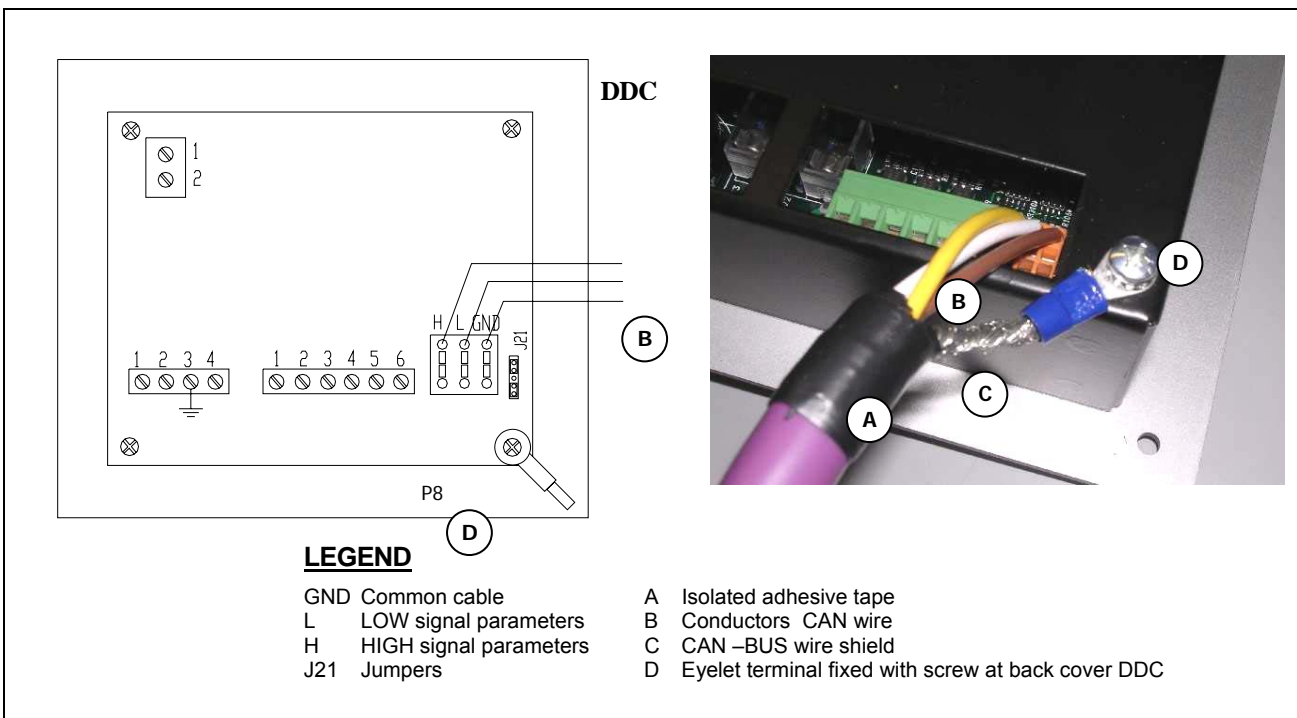

Figure 25 – EXAMPLE OF CAN-BUS WIRE CONNECTION TO DDC (only one entry CAN-BUS wire)

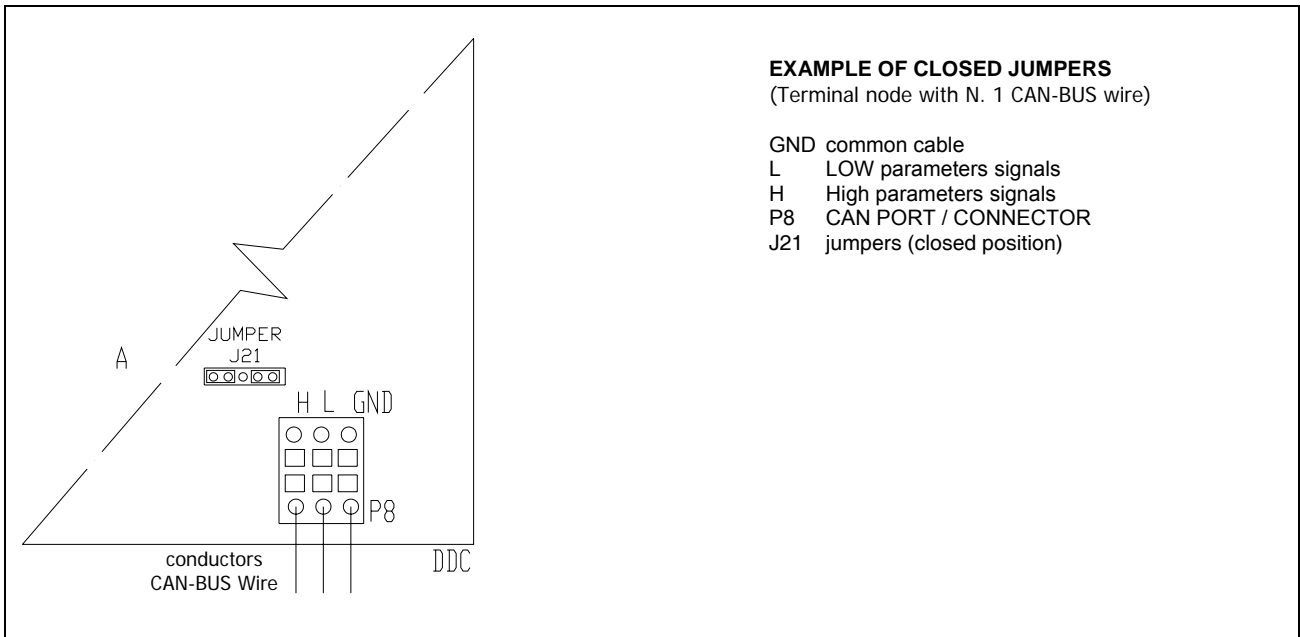

Figure 26 – DETAILED EXAMPLE OF ONE CAN-BUS WIRE CONNECTION TO DDC

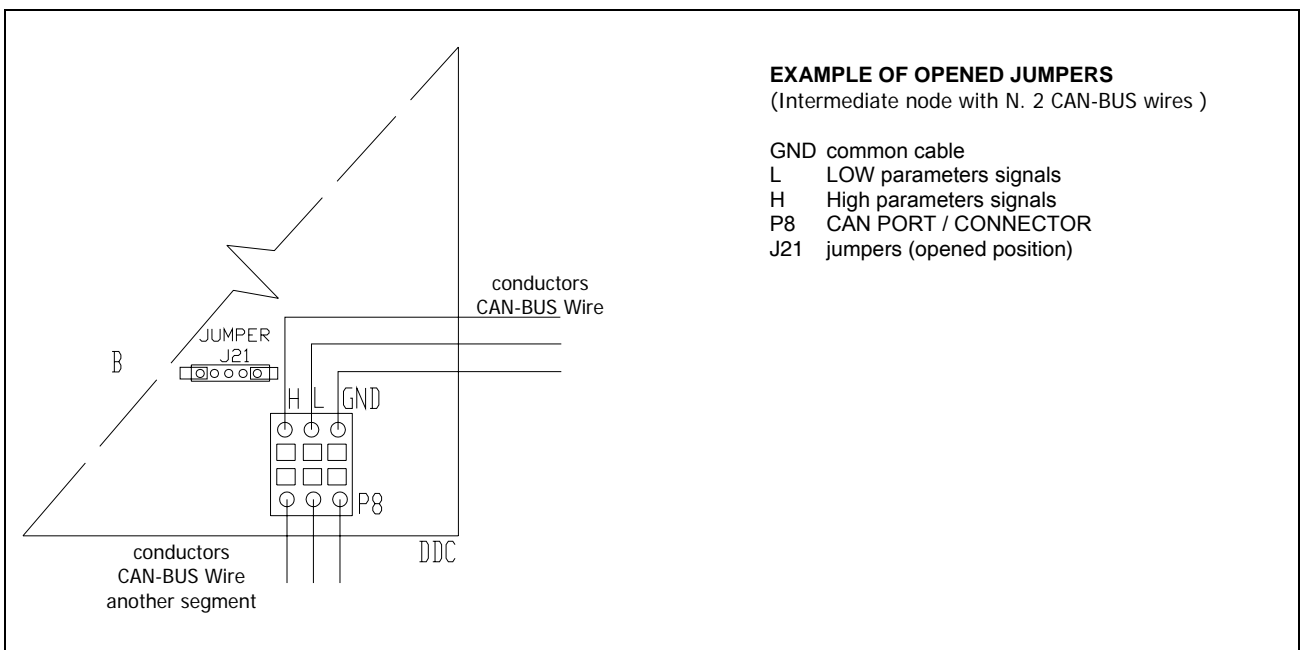
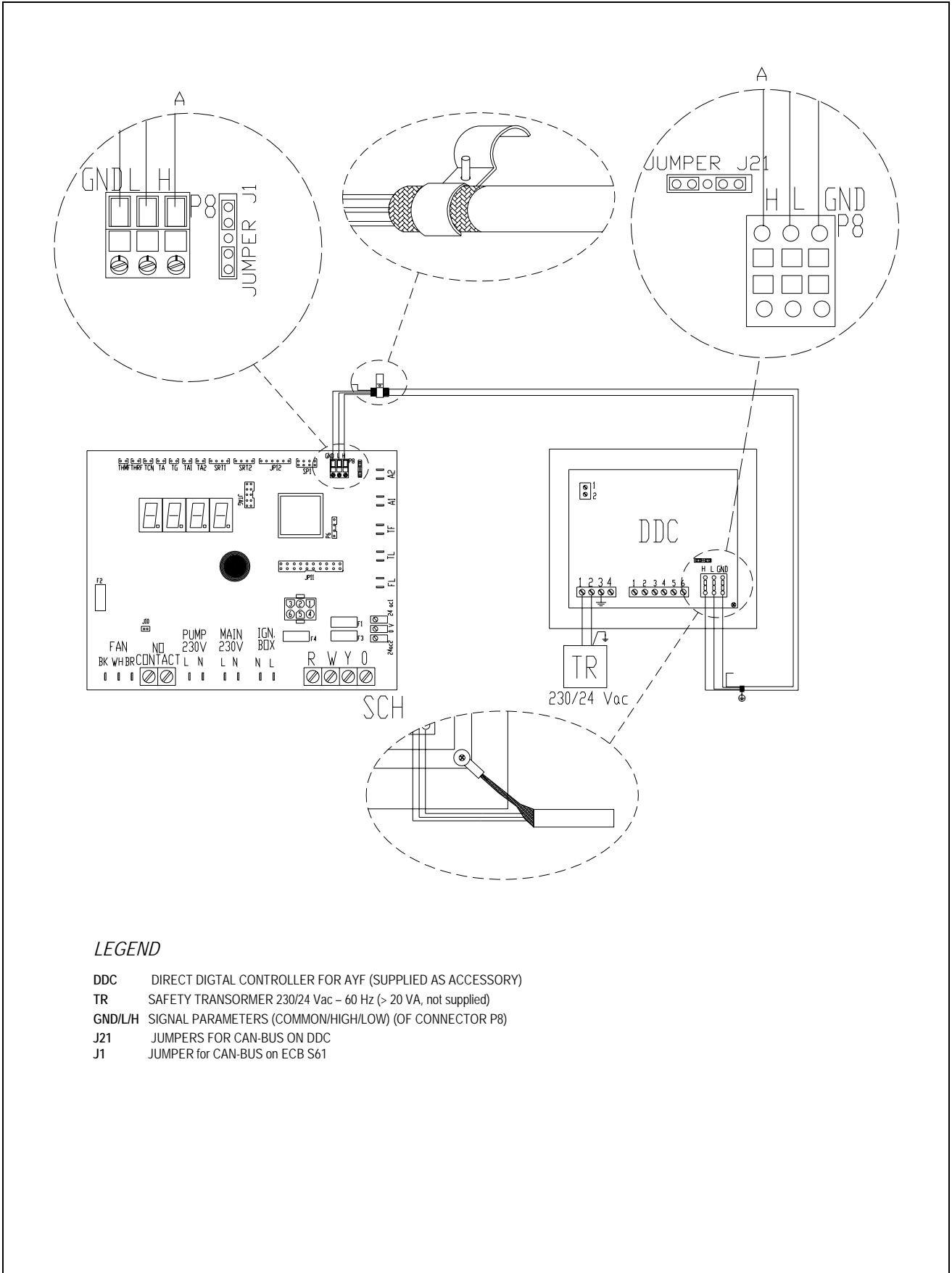

Figure 27 – DETAILED EXAMPLE OF TWO CAN-BUS WIRES CONNECTION TO DDC



LEGEND

- DDC DIRECT DIGITAL CONTROLLER FOR AYF (SUPPLIED AS ACCESSORY)
- TR SAFETY TRANSFORMER 230/24 Vac – 60 Hz (> 20 VA, not supplied)
- GND/L/H SIGNAL PARAMETERS (COMMON/HIGH/LOW) (OF CONNECTOR P8)
- J21 JUMPERS FOR CAN-BUS ON DDC
- J1 JUMPER for CAN-BUS on ECB S61

Figure 28 – CONNECTION OF DDC TO N. 1 ACF60-00.

6. START-UP AND ADJUSTMENT

WARNING

This unit should be started-up by Authorized Engineers according to the manufacturer's instructions. The end-user is not authorized to perform start-up and adjustment operations.

If during the first start-up (in site) a DANGEROUS or ANOMALOUS situation is met due to non-conform system, the start-up operations won't be completed. The user/installer must perform the proper adjustments indicated by authorized engineers, who will carry out the start-up.

The positive result of the first start-up (in site) is only reflecting the good operation of the unit and DDC (if used), but doesn't involve any responsibility concerning the correct execution of the system.

The length of the warranty is dependent upon the installation and start-up of the unit by Authorized Technicians. See warranty card for complete details.

DANGEROUS SITUATIONS FOR THE UNIT AND/OR PERSONS

If up on performing the 1st start-up, and one of the following conditions is found **don't proceed with the start-up**:

- Unit installed indoors, or in position unsafe for servicing and maintenance.
- The unit turned on and off by using the main electrical switch (not using control switch).
- Antifreeze mono-ethylene glycol not added to the water
- Unit damaged or defective due to transport and/or installation

ANOMALOUS INSTALLATION CONDITIONS FOR THE UNIT AND/OR PERSONS

The Authorized ROBUR Service can carry out the 1st start-up, but **the unit will be kept switched off** until the user/installer fully follows the manufacturer's directions/instructions. Anomalous installation conditions:

- Installations which show situations in contradiction to the directions/instructions of the manufacturer in part or fully;
- Installations which show situations which result or may result as a defective unit operation.

6.1 FILLING THE WATER PIPING

WARNING

To ensure correct operation of the unit and to avoid the water freezing, add 10% by volume of inhibited mono-ethylene glycol (antifreeze) to the circulation water. Add more mono-ethylene glycol as needed for the minimum external temperature of the installation zone (see Table 18, page 55).

The method described below is **only one of several ways** that can be used to fill the hydronic circuit. A container to mix water and mono-ethylene glycol and a water pump to drive the mixture into the hydronic system is required; 2 valves are placed on the circuit as shown in Figure 30.

1. Open air bleed(s) located at the highest point in the system. Connect a hose between the charging pump and Valve A. Connect a hose to Valve C and place the other end of this hose into the mixing container (See Figure 21).
2. Mix the desired concentration and volume of water/antifreeze in the container. If the container will not hold the volume required to fill hydronic circuit, multiple "batches" must be made.
3. Close Valve B. Open Valve A and Valve C. Start charging pump to push the water/antifreeze mixture into the hydronic system. Air will be removed through the hose on Valve C as the hydronic system fills. Continue to fill the system until the water/antifreeze mixture returns to the mixing container via the hose on Valve C.
4. If the volume in the mixing container is adequate to fill the hydronic system, skip to Step 14. If the volume in the mixing container is inadequate to fill the hydronic system, close Valve A prior to air entering the charging pump and shut the charging pump off.
5. Make a new container of water/antifreeze mixture.
6. Start the charging pump and open Valve A to continue filling hydronic system. Repeat Steps 4 through 6 as needed until hydronic system is filled or until charging pump is incapable of adding any additional mixture due to pump discharge head limitations.
7. If the system is filled, skip to Step 14. If the system is not full, turn on the hydronic system's pump but do not start the unit. Jumping the N.O. CIRC. contacts on the electronic control board can start the hydronic system's pump.
8. "Throttle" Valve B, if necessary to continue filling the hydronic system if the system does not start filling after the hydronic system pump was started.
9. If the volume in the mixing container is not sufficient to fill the hydronic system, close Valve A prior to air entering the charging pump and shut both pumps off.
10. Mix new container of water/antifreeze mixture.
11. Start both pumps and open Valve A.
12. Repeat Steps 9 through 11 until the system is filled and all air is removed from the hydronic system.
13. Close Valve A and Valve C. Shut off all pumps. Open Valve B.
14. Close any manual air bleed valves.
15. Start pumps and open Valve A.
16. Add additional inhibited antifreeze/water mixture until the hydronic system has a total pressure of at least 20 psig or sufficient pressure in the system to allow a positive pressure at pump suction at all times.
17. Close Valve A and shut down both pumps.
18. Disconnect the charging pump and the mixing container.
19. The hydronic system is now charged.

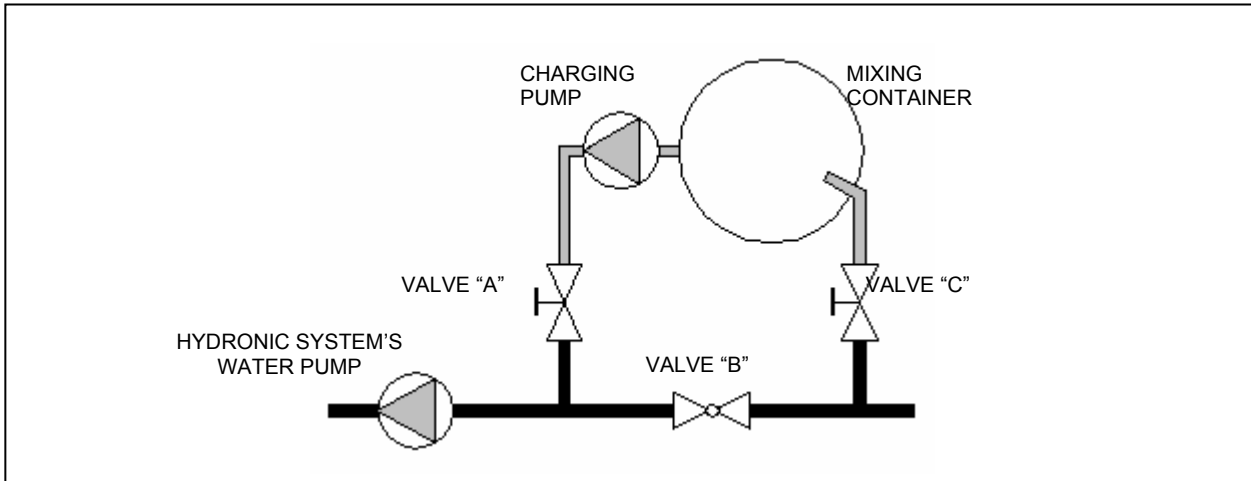

Figure 30 – COMPONENTS USED IN FILLING THE HYDRONIC SYSTEM

| TYPE OF ANTIFREEZE | APPROXIMATE PERCENTAGE OF ANTIFREEZE BY VOLUME | | | |
|----------------------|--|-----|-------|-------|
| | 20 | 30 | 40 | 50 |
| MONO-ETHYLENE GLYCOL | 16°F | 4°F | -12°F | -35°F |

Table 18 – FREEZING POINTS OBTAINED BY VARIOUS CONCENTRATIONS OF MONO-ETHYLENE GLYCOL ANTIFREEZE

6.2 GAS PRESSURE ADJUSTEMENT

The manufacturer supplies the units already adjusted for a particular type of gas. The type of gas can be checked and easily identified by looking at the marking label inside the unit. Nevertheless, before starting the unit it is necessary to check and adjust if necessary the Gas Input (HHV) to the burner. Using the table below, arrange the proper manifold pressure according to the local gas heating value (BTU content per cubic foot) and specific gravity. This table is based on the correct natural Gas Input (HHV) for the model by manifold pressure in inches of water column (in WC).

| MJ CONTENT PER CU.Meter | BTU CONTENT PER CU.FT. | SPECIFIC GRAVITY OF NATURAL GAS | | | |
|-------------------------|------------------------|---------------------------------|------|------|------|
| | | 0,55 | 0,6 | 0,65 | 0,7 |
| 35,40 | 950 | 2,81 | 3,07 | 3,33 | 3,58 |
| 36,33 | 975 | 2,67 | 2,91 | 3,16 | 3,40 |
| 37,26 | 1000 | 2,54 | 2,77 | 3,00 | 3,23 |
| 38,19 | 1025 | 2,42 | 2,64 | 2,86 | 3,08 |
| 39,12 | 1050 | 2,30 | 2,51 | 2,72 | 2,93 |
| 40,05 | 1075 | 2,20 | 2,40 | 2,60 | 2,80 |
| 40,98 | 1100 | 2,10 | 2,29 | 2,48 | 2,67 |
| 41,92 | 1125 | 2,01 | 2,19 | 2,37 | 2,55 |

Nostro riferimento:

| MJ CONTENT PER CU.Meter | BTU CONTENT PER CU.FT. | SPECIFIC GRAVITY OF NATURAL GAS |
|-------------------------|------------------------|---------------------------------|
| | | 0,555 |
| 37,78 | 1014 | 2,5 |

Table 19 - MANIFOLD PRESSURE BASED ON GAS INPUT (HHV) OF 94,900 Btu/hr USING 0.21" ORIFICE.

The conditions referred to by the table above are for the guidance of the installer and the CSA design certification does not cover the conditions described therein.

Note: For Propane Gas Models, follow the same instructions as given for natural gas. The manifold pressure for propane gas should be 4.8" W.C. and adjustment is made at the gas valve regulator. Manifold pressure at 94,900 Btu/hr. input using 0.14" orifice.

| GAS TYPE | NATURAL GAS | LP GAS |
|-------------------|---------------|---------------|
| MANIFOLD PRESSURE | 2.5 WC Inches | 4.8 WC Inches |
| NOZZLE DIAMETER | 0.21" | 0.14" |

Table 20 - MANIFOLD PRESSURE AND NOZZLE DIAMETER

PRESSURE ADJUSTMENT PROCEDURE

1. Turn main gas valve knob to the "OFF" position.
2. Remove the plug on Outlet end of gas valve and attach pressure tap and manometer.
3. Turn power "ON," and close control switch.
4. Wait for the burner to start up. Due to the presence of air inside the piping, it may be that the burner does not start at the first three attempts and failing to do so the ignition system is locked out. If this happens reset the ignition system (see dedicated procedure, end of Appendix). Repeat until all the air is purged from the piping and the burner ignites.
5. When the burner ignites read the manometer and compare to the required pressure in Table 19.
6. If necessary change the manifold pressure using the gas valve regulator. The regulator is built into the gas valve. Remove the seal screw and turn adjusting screw clockwise to increase pressure or counter clockwise to reduce pressure. Replace seal screw after adjustment.
7. Open control switch and make sure unit is off.
8. Remove manometer and pressure tap. Replace plug in gas valve.
9. Turn unit on by closing control switch. Check all gas connections with soap for leaks.

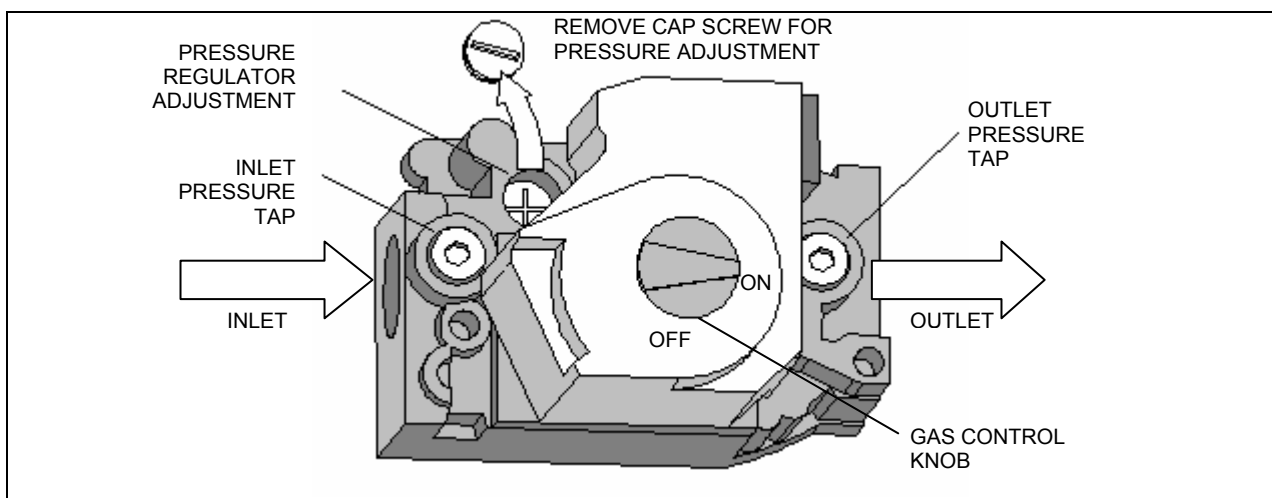

Figure 31 – GAS VALVE

6.3 CHILLED WATER TEMPERATURE REGULATION

When DDC is used, the following menu3 set-up is not to be done. It's necessary to consult "Installation and Programming manual of DDC - Direct Digital Controller".

If the unit isn't connected to a DDC, chilled water temperature regulation can be set up from menu 3 of the S61 card (see APPENDIX: S61 electronic card).



| MENU 3 – End User Adjustment | |
|---|--|
| MENU SIGNALS | DESCRIPTION OF MENU SIGNALS |
|  | Thermostat action |
|  | Cold water set point |
|  | Cold water temperature difference ΔT |
|  | Exit |

Table 21 – MENU 3 PARAMETERS

The **thermostat action** parameter can assume 2 values: 0 and 1. When 0 is set, temperature to drive the unit is read by the INLET probe; when 1 is set, the temperature is read by the OUTLET probe.

The **set-point** is intended to be the pre adjusted water temperature (in/out), when being achieved, the unit will start the switching off cycle as (since) the conditioning request is met. This parameter can assume values from a factory set minimum value up to 77°F.

The **temperature difference** is intended to be a value, which should be summed up by the pre adjusted set point temperatures. This parameter can assume values from 1.8°F up to 14.4°F.

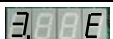
The obtained value represents the water temperature. According to this temperature, the conditioning request will be re activated and then the unit will start-up again .

For example, let us suppose the following adjustments :

- Thermostat action: unit operation with outlet temperature
- set-point **+44°F**;
- Temp. difference **2** ;

The unit behaves as follows :

- One time during the unit operation, the water of HYDRONIC system is getting cold until the outlet water temperature reaches **+44°F** (set-point temperature);
- Up on achieving that temperature, the unit will be switched off automatically.
- When the water temperature starts getting high, reaches **+46°F** (that is **+44°F** plus the temp difference of **2**) the unit will start-up again to cool the water once more until reaching **+44°F**, and so on.

Then, according to these adjustments the unit switches off at **+44°F** and starts-up at **+46°F**.

To set up the parameters use the encoder knob:

- To select a menu, a parameter or a value rotate the knob.
- To enter a value press the knob

(see APPENDIX: Electronic system of the ACF60-00 unit).

7. SERVICING AND MAINTENANCE

This manual is an integral and essential part of the product and must be given to the owner.

Performing correct preventive service and maintenance will help to guarantee long life of the unit with high efficiency and low maintenance costs.

WARNING

ONLY Authorized Technicians strictly complying with the manufacturer's instructions and the local standards should perform maintenance and service on the UNIT internal components.

Lubrication of condenser fan, hydraulic pump, and pre-mixer motor is not recommended.

The operations described below must be performed once a year. If the unit is installed on a heavy-duty installation (industrial plants, 24hr operation etc.), it is necessary to increase the frequency of checks and services.

Maintenance to be performed on the unit:

- Cleaning of the condenser /absorber coils
- Check condenser fan height

NOTE

Before any type of service is performed, ALWAYS shut-off the power supply at the main switch.

CLEANING THE CONDENSER / ABSORBER COILS

It is recommended to clean the condenser / absorber coils regularly since the UNIT cooling capacity can be greatly reduced by dirt on the coils (see Figure 32). The user, installer or service technician can perform this operation. To clean condenser / absorber coil proceed as follows:

1. Shut off the power and gas supply.
2. Remove the covering panels.
3. Use a brush to remove dirt from the outside and inside of the condenser/absorber coils.
4. Using water pressure, wash the coils from in to out and from top to bottom. Care should be taken not to spray electrical components or to damage the aluminum fins.
5. Check that all dirt is removed.
6. Replace the panels.
7. Turn on the power and gas supply.
8. Start unit to check for correct operation.

NOTE

Do not use solvents for cleaning the condenser/absorber coils; this could cause damage to the aluminum fins.

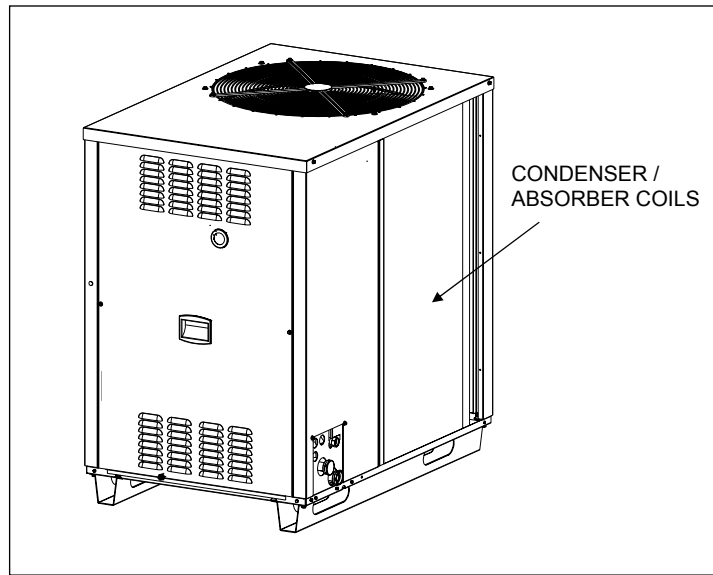

Figure 32 – FINNED CONDENSER / ABSORBER

WARNING
ALWAYS wear safety goggles!

BURNER CONTROL

Gas burners do not normally require scheduled servicing; however, deterioration or an accumulation of lint may cause yellowing flame or delayed ignition. Either condition indicates that a service call is required.

CHECK CONDENSER FAN HEIGHT

For proper air flow, the distance between the top edge of the fan blade and the top panel must be 1"1/4. If the fan is at an improper height, adjust the location of the mounting strap around the fan motor.

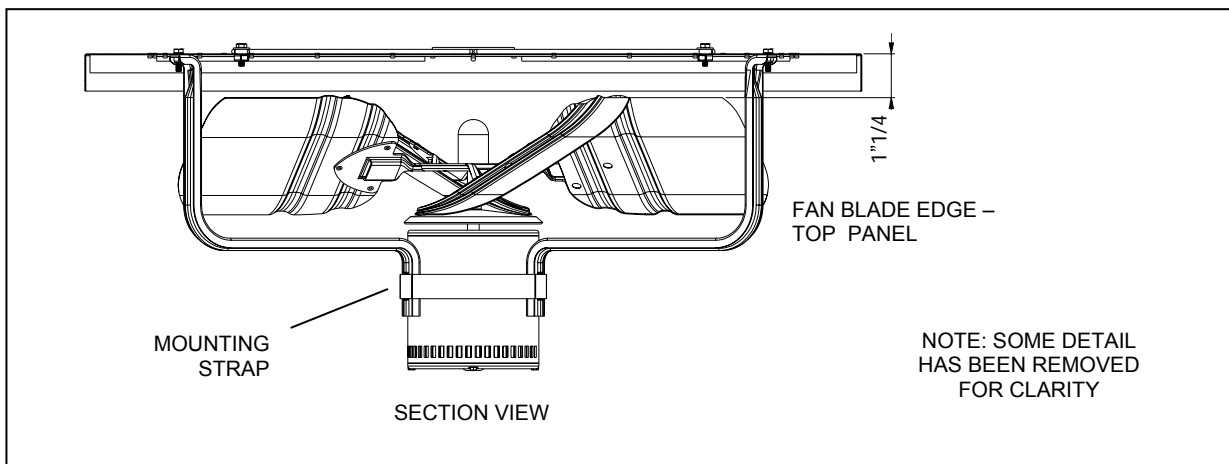

Figure 33 – SECTION VIEW SHOWING PROPER FAN HEIGHT

8. ADAPTING TO ANOTHER GAS

NOTE

ONLY an Authorized Technician can perform the operation described in this section.

If the type of gas indicated does not correspond to the type to be used (natural or propane gas) by unit, it must be converted and adapted to the type of gas to be used. The gas orifice (nozzle) must be changed and the gas valve must be converted.

For this operation proceed as follows:

1. Turn off the gas and electrical supply, remove front and left panel.
2. Remove the wires from the gas valve.
3. Remove the ring nut from the threaded gas nozzle.
4. Remove the gas nozzle from gas valve by removing the 4 screws from the valve flange (use 9/64 hex key wrench). Put the o-ring in a safe place, to be re-used with the new nozzle.
5. Attach the new gas nozzle to the gas valve using the 4 screws to secure valve flange: be sure to put the o-ring in the proper site.
6. Tighten the ring nut and re-attach wires to the valve.
7. Turn on the gas and electrical supply.
8. Adjust the gas pressure for the gas to be used following the instructions reported in **SECTION 6.3 "GAS PRESSURE ADJUSTMENT"**.
9. Replace the stickers indicating the type of gas for which the unit is preset with the new one, which indicates the type actually being used.

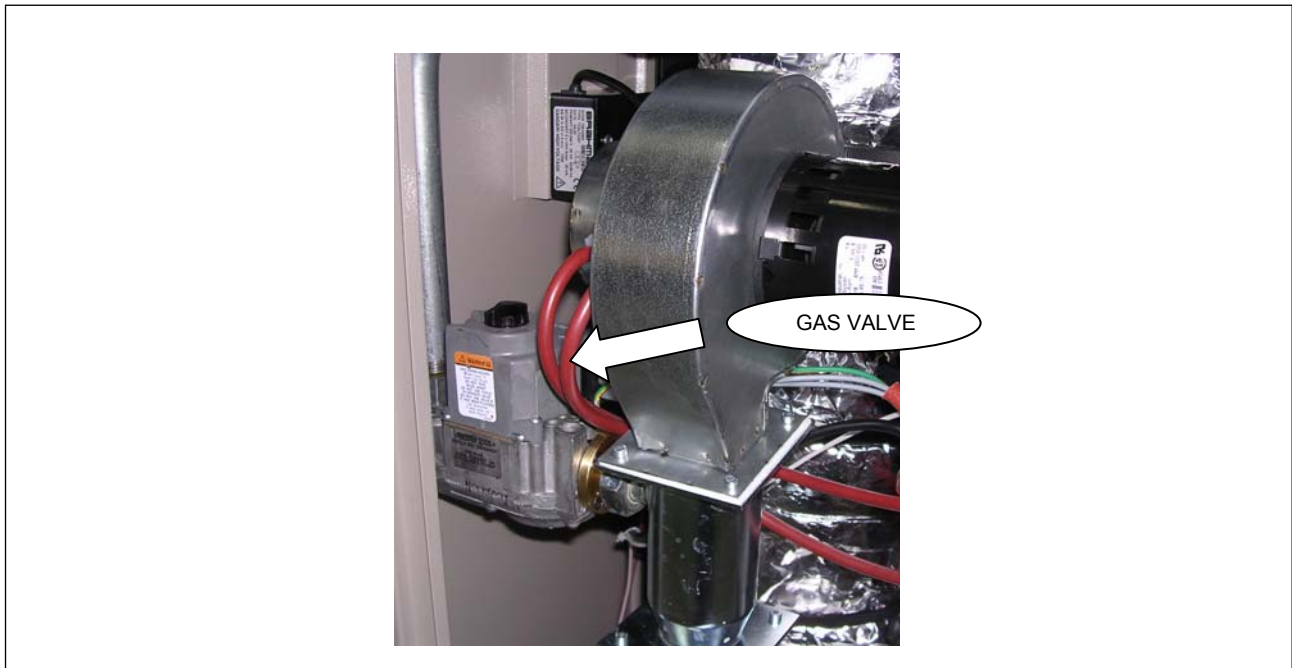

Figure 34 – GAS VALVE

9. SPARE PARTS

Below are the lists of the spare parts for ACF60-00 appliance. Each list comes after the respective exploded drawing, which pictures each part in the list with its progressive number.

Spare parts can be ordered from Robur S.p.A. .

Exploded drawing n.1: INSULATING, WATER PIPES AND ACCESSORIES

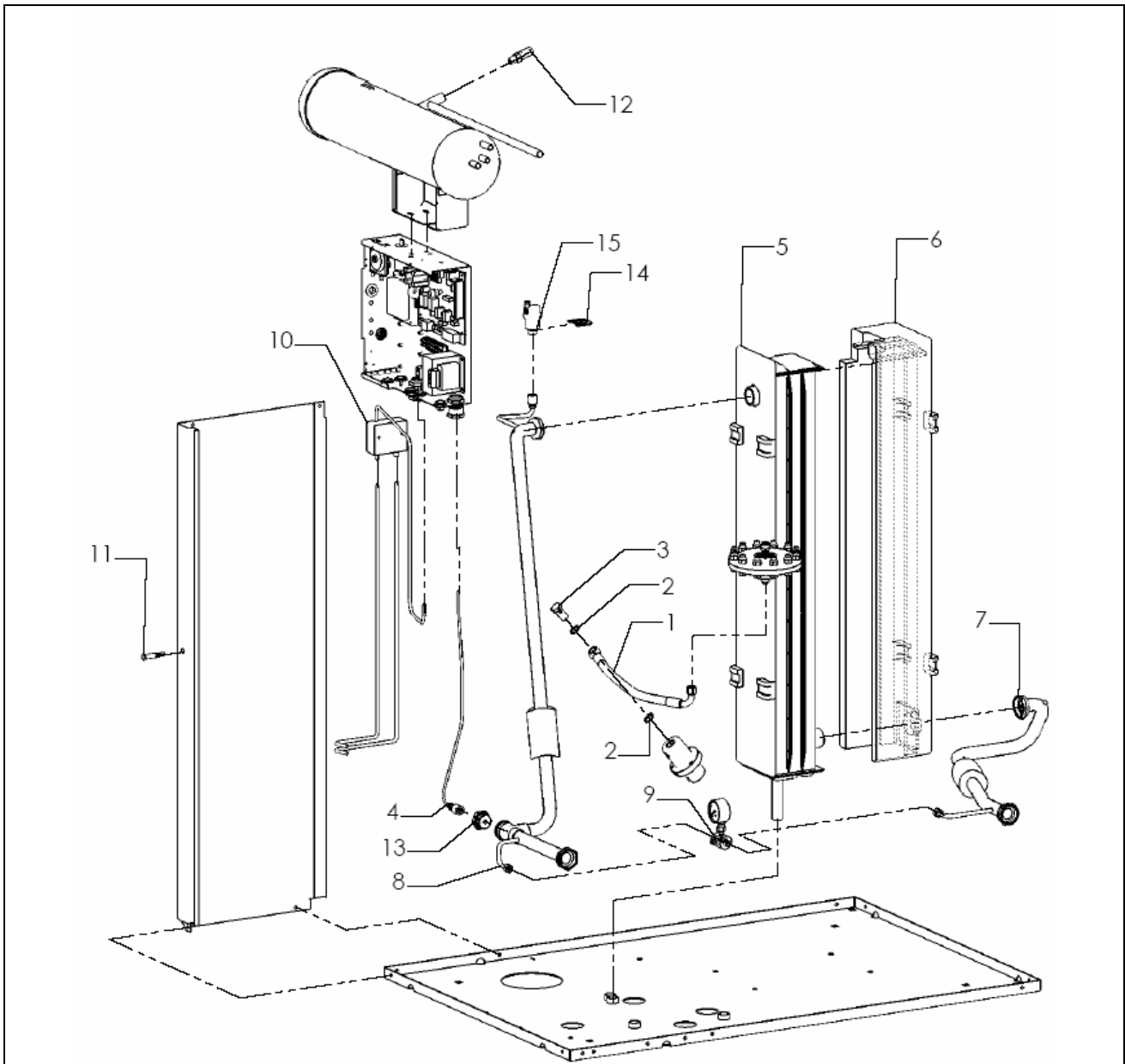

Figure 35 – EXPLODED DRAWING N.1 – SEE Table 22, PAGE 64 FOR THE RELATIVE PARTS LIST.

| Rif. | Codice | Descrizione | Q.tà |
|------|----------|--------------------------------|------|
| 1 | J-TBO358 | PUMP HIGH PRESSURE PIPE | 1 |
| 2 | N-RND016 | D.3/8"x1,5 COPPER WASHER | 2 |
| 3 | N-BLL000 | PUMP GAS SCREW 3/8" | 1 |
| 4 | J-FLS009 | WATER FLOWSWICH FOR S61 | 1 |
| 5 | C-CBN091 | ABSORBER FRONT-SIDE INSULATING | 1 |
| 6 | C-CBN092 | ABSORBER REAR-SIDE INSULATING | 1 |
| 7 | R-TBO418 | WATER DELIVERY PIPE | 1 |
| 8 | R-TBO420 | WATER RETURN PIPE | 1 |
| 9 | K-MNM002 | DIFFERENTIAL MANOMETER KIT | 1 |
| 10 | J-TRS007 | IGNITER TRANSFORMER | 1 |
| 11 | E-LMP013 | SIGNAL LIGHT 230V WITH FAST-ON | 1 |
| 12 | G-VLV032 | PRESSURE RELIEF VALVE | 1 |
| 13 | R-GFS001 | FLOWSWICH CLAMPING RING NUT | 1 |
| 14 | L-STF189 | AIR BREATHER VALVE BRACKET | 1 |
| 15 | H-VLV000 | AUTOMATIC AIR BREATHER VALVE | 1 |

Table 22 – SPARE PARTS PICTURED IN Figure 35: INSULATING, WATER PIPES AND ACCESSORIES

Exploded drawing n.2: ELECTRICAL BOX AND PUMP

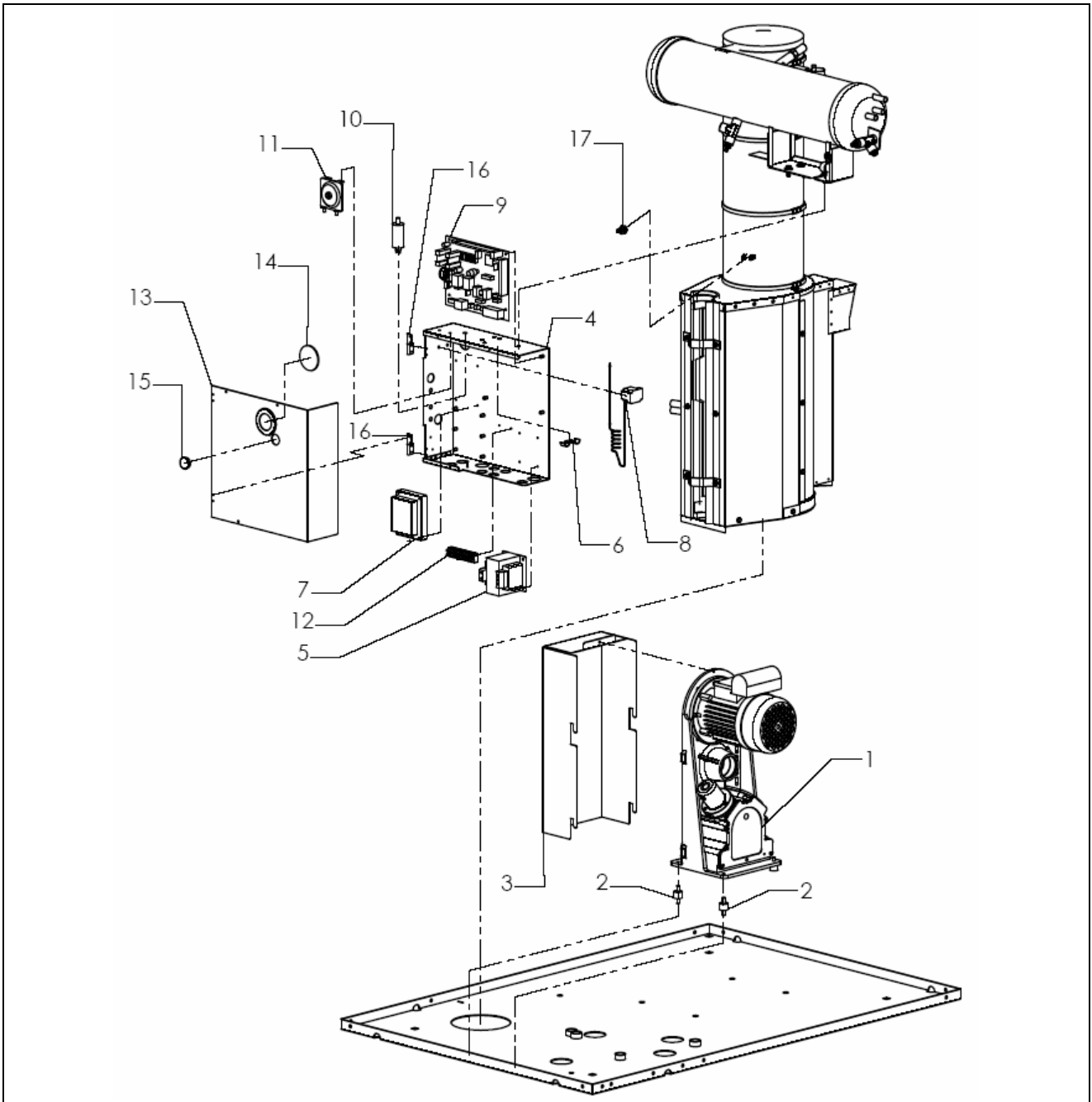

Figure 36 – EXPLODED DRAWING N.2 – SEE Table 23, PAGE 66 FOR THE RELATIVE PARTS LIST.

| Rif. | Codice | Descrizione | Q.tà |
|------|------------|--|------|
| 1 | R-PMP009 | 60 Hz OIL PUMP | 1 |
| 2 | J-NTV000/B | MX20/15 VIBRATION DAMPING | 2 |
| 3 | J-CRT003 | PUMP CARTER | 1 |
| 4 | L-BQD018 | ELECTRIC PANEL BASE | 1 |
| 5 | E-TRS013 | 60 Hz 208-240/24V/40VA ELECTRICAL TRANSFORMER | 2 |
| 6 | L-STF149 | GROUND CONNECTION BRACKET | 1 |
| 7 | E-CNT031 | 24 Vac, 60Hz, MICROPROCESSOR BASED HSI CONTROL | 1 |
| 8 | J-TLT020 | COMBUSTION CHAMBER THERMOSTAT | 1 |
| 9 | E-SLT040 | S61CF24 ELECTRICAL BOARD | 1 |
| 10 | E-CND011 | CONDENSER 12.5 μ F 450 V | 1 |
| 11 | G-PRS000 | AIR PRESSURE SWITCH ACF60.2 60 Hz | 1 |
| 12 | E-MRS020 | 9 STUD TERMINAL BOARD WITH REED | 1 |
| 13 | L-CQD011 | ELECTRIC BOX COVER | 1 |
| 14 | C-12100960 | INSPECTION HOLE GLASS | 1 |
| 15 | N-TPP019 | D.25 PROTECTION CAP | 1 |
| 16 | N-CRN000 | ELECTRIC BOX HINGE | 2 |
| 17 | J-TLT015 | LIMIT THERMOSTAT FOR GENERATOR | 1 |

Table 23 – SPARE PARTS PICTURED IN Figure 36: ELECTRICAL BOX AND PUMP

Exploded drawing n.3: COMBUSTION CHAMBER AND GAS SYSTEM

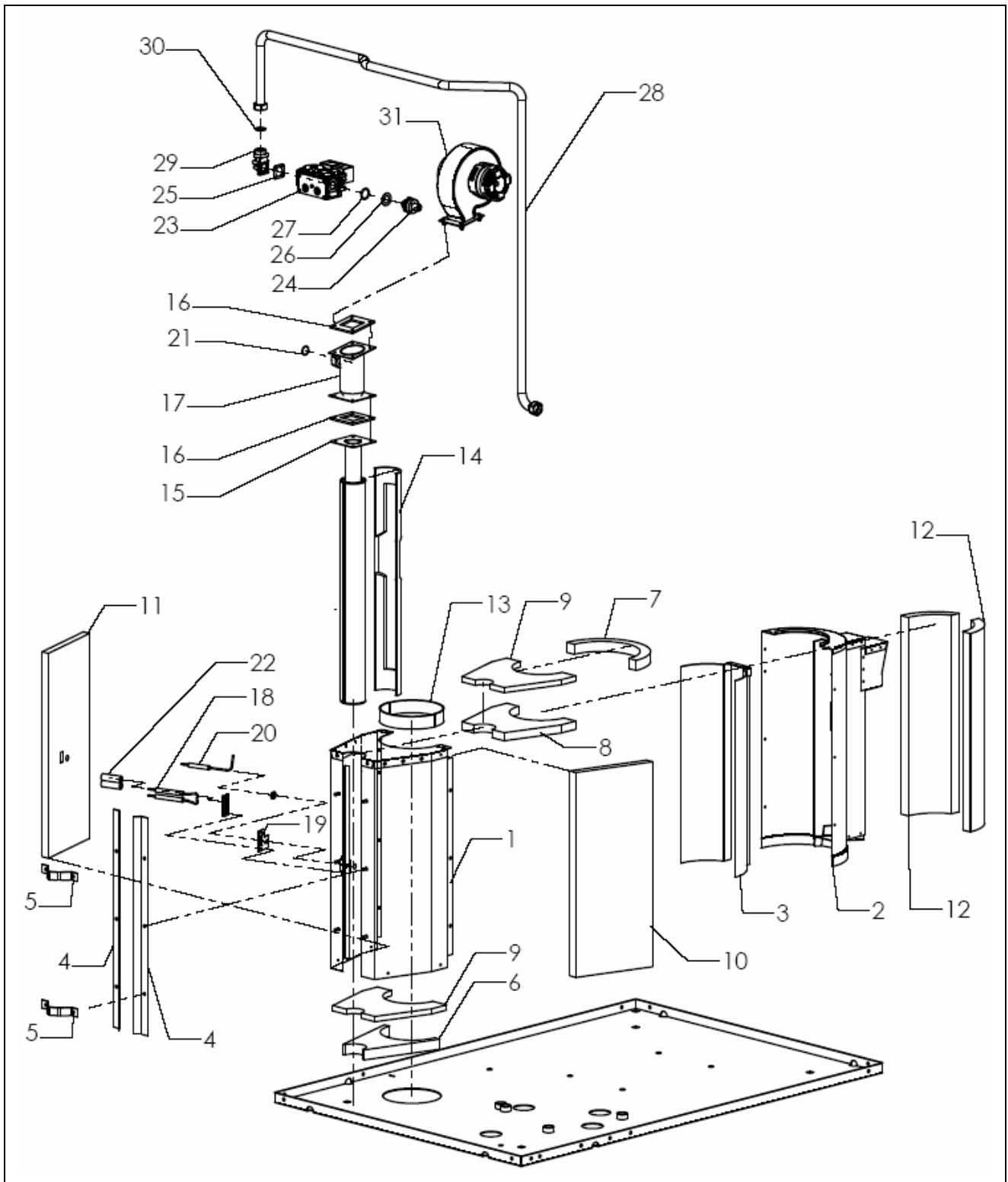

Figure 37 – EXPLODED DRAWING N.3 – SEE Table 24, PAGE 68 FOR THE RELATIVE PARTS LIST.

| Rif. | Codice | Descrizione | Q.tà |
|------|----------|------------------------------------|------|
| 1 | J-CCM026 | FRONT COMBUSTION CHAMBER ASSY | 1 |
| 2 | S-CMR000 | REAR COMBUSTION CHAMBER ASSY | 1 |
| 3 | H-CMR002 | COMB. CHAMBER INTERNAL CONVEYOR | 1 |
| 4 | L-STF120 | RETAINER BURNER | 2 |
| 5 | L-MFS000 | BURNER TUBE CLIP | 2 |
| 6 | C-CBN040 | FRONT BOTTOM INSULATION | 1 |
| 7 | C-CBN038 | REAR UPPER INSULATION | 1 |
| 8 | C-CBN037 | FRONT-TOP INSULATION | 1 |
| 9 | C-CBN042 | COMBUST. CHAMBER BASE INSULATION | 2 |
| 10 | C-CBN080 | RIGHT COMBUST. CHAMBER INSULATION | 1 |
| 11 | C-CBN081 | LEFT COMBUST. CHAMBER INSULATION | 1 |
| 12 | C-CBN039 | COMB. CHAMBER REAR-SIDE INSULATION | 2 |
| 13 | C-CBN041 | COMB. CHAMBER/GENERATOR INSULATION | 1 |
| 14 | J-CBN029 | BURNER INSULATION | 1 |
| 15 | J-BRC017 | BOILER BURNER | 1 |
| 16 | J-GRN028 | BURNER UNION TRIMMING | 2 |
| 17 | R-DFF009 | INCLINED AIR-GAS MIXER | 1 |
| 18 | J-LTT047 | SPARKLING ELECTRODE | 1 |
| 19 | C-GRN086 | SENSOR FLAME ELECTRODE GASKET | 1 |
| 20 | J-LTT046 | SENSOR FLAME ELECTRODE | 1 |
| 21 | N-GRG006 | 2075 NB 70 O-RING | 1 |
| 22 | J-CSL000 | D.11/16 x 50 CERAMIC INSULATION | 1 |
| 23 | G-VLV052 | 24 VAC GAS CONTROL VALVE | 1 |
| 24 | B-GLL150 | Ø 5.3 METHANE NOZZLE | 1 |
| | B-GLL153 | Ø 3.6 GPL NOZZLE | 1 |
| 25 | C-GRN041 | 24x24 GAS PIPE GASKET | 1 |
| 26 | C-GRN040 | 1" GASKET | 1 |
| 27 | N-GRG000 | 3087 NBR NT 70 O-RING | 1 |
| 28 | R-TBO645 | GAS TUBE COMPONENT | 1 |
| 29 | G-FLN019 | 90° ½" NPT GAS VALVE FLANGE | 1 |
| 30 | C-GRN057 | CENTELLEN 200 ¾" GASKET | 1 |
| 31 | K-SFF038 | BLOWER KIT | 1 |

Table 24 – SPARE PARTS PICTURED IN Figure 37: COMBUSTION CHAMBER AND GAS SYSTEM

Exploded drawing n.4: PANELS KIT

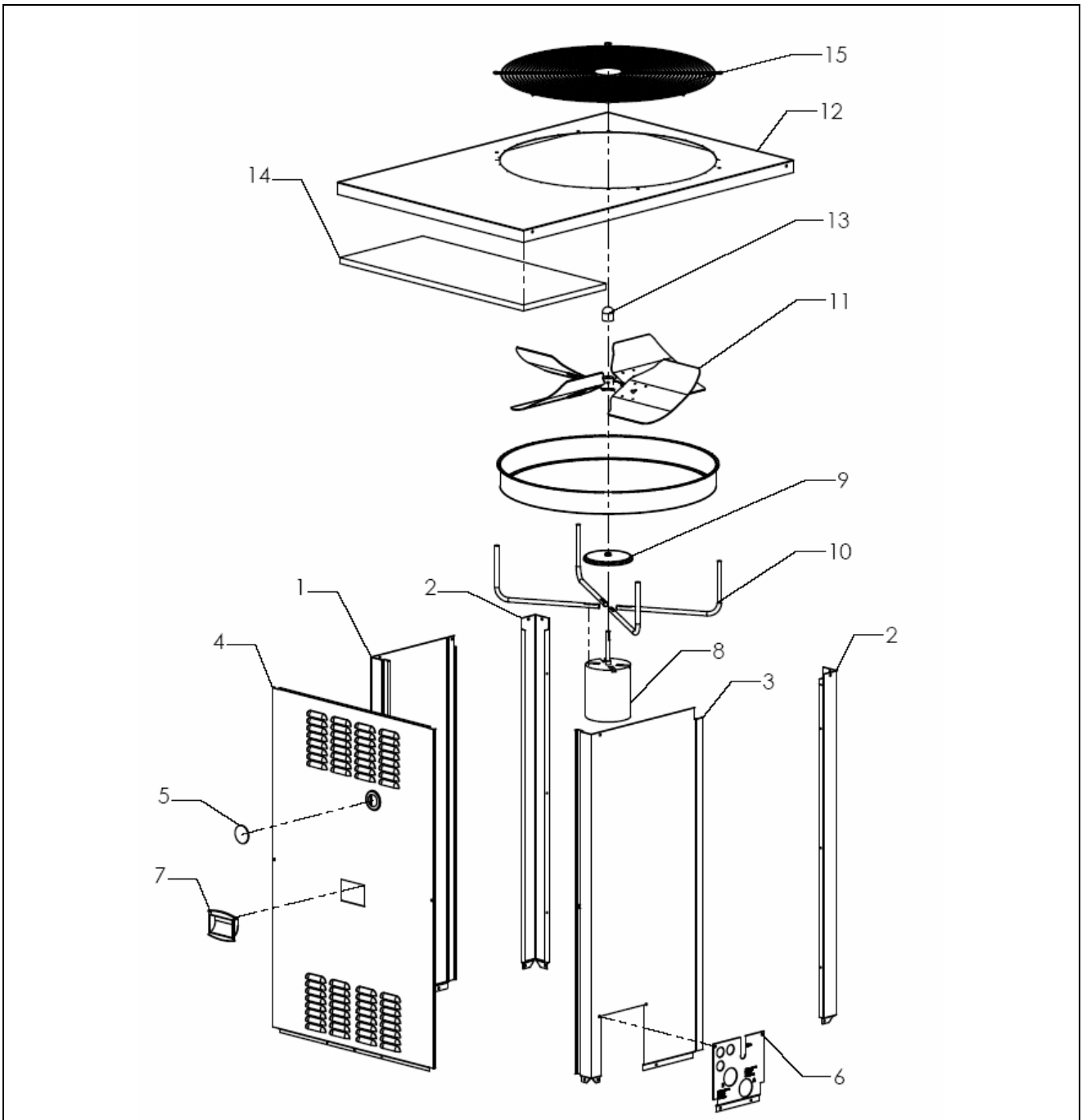

Figure 38 – EXPLODED DRAWING N.4 – SEE **Table 25**, PAGE 70 FOR THE RELATIVE PARTS LIST.

| Rif. | Codice | Descrizione | Q.tà |
|------|------------|--------------------------------------|------|
| 1 | P-MNS035 | PAINTED FRONT-LEFT COLUMN | 1 |
| 2 | P-MDS004 | PAINTED BACK RIGHT-LEFT COLUMN | 2 |
| 3 | P-MND020 | PAINTED FRONT-RIGHT COLUMN | 1 |
| 4 | P-PNF063 | COMPLETE PAINTED FRONT PANEL | 1 |
| 5 | C-12100960 | INSPECTION HOLE GLASS | 1 |
| 6 | L-PST068 | SILK SCREENED SERVICE PLATE | 1 |
| 7 | N-MNG000 | PANELS HANDLE | 1 |
| 8 | E-MTR056 | 60 Hz FAN MOTOR | 1 |
| 9 | V-PRT000 | 60 Hz MOTOR RAIN SHIELD | 1 |
| 10 | L-STF210 | 60 Hz FAN MOTOR BRACKET | 4 |
| 11 | V-VNT025 | BLADE ASSEMBLY – FAN – 26” Ø – 60 Hz | 1 |
| 12 | P-CPR048 | PAINTED SUPERIOR PANEL | 1 |
| 13 | N-TPP061 | Ø33.4 H.25 VINYL CAP | 1 |
| 14 | C-CBN028 | 380X840 SUPERIOR PANEL INSULATION | 1 |
| 15 | J-GPR000 | FAN GRID | 1 |

Table 25 - SPARE PARTS PICTURED IN Figure 38: PANELS KIT

10. APPENDIX

ELECTRONIC SYSTEM OF THE ACF60-00 UNIT

The **electronic control board of the unit** is placed inside the electrical box and is equipped with a 4 digits display, a regulating knob (*encoder*) and a terminal set (CAN PORT) for the remote connection.

The DISPLAY (particular **A**) shows the operation data (example: chilled water temperature) and possible anomalies, through the visualization of the unit codes.

Besides, It is possible to visualize all relative available information (data, parameters, values, etc.).

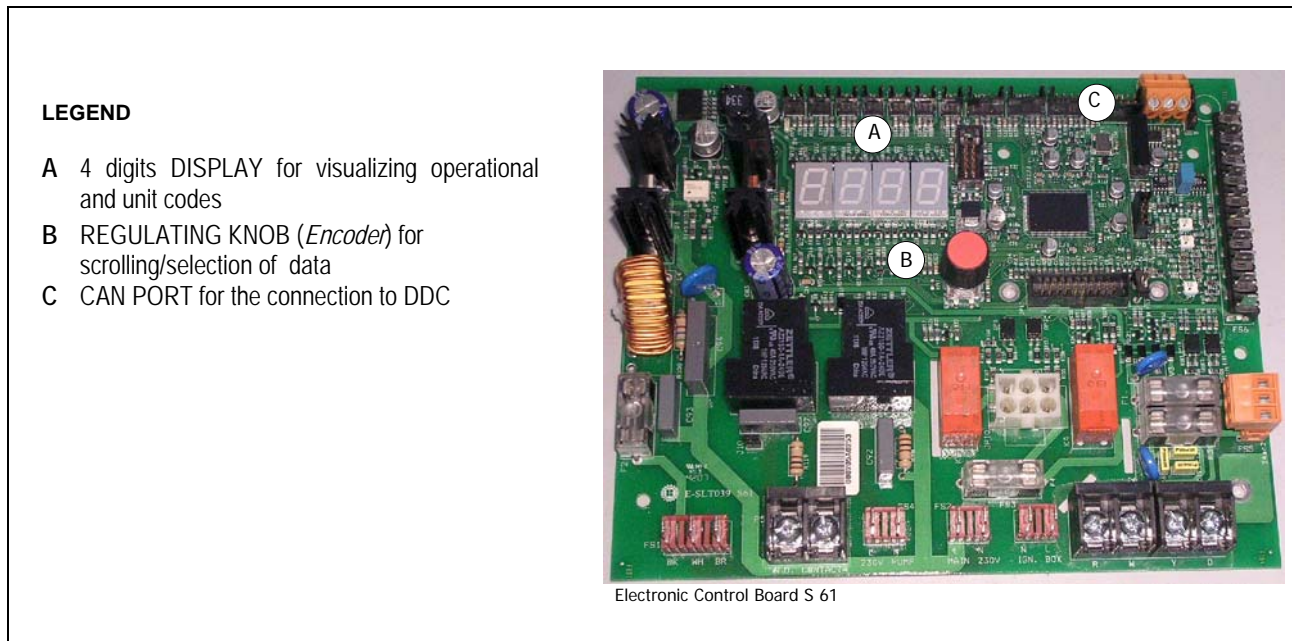

Figure 39 – ELECTRONIC CONTROL BOARD DETAIL

Rotating and pressing the REGULATING KNOB (particular **B**) allows the scrolling and selection of the information on the display.

Through the regulating knob and Display, operation management and control take place.

The CAN PORT (particular **C**) allows the connection, by one can-bus wire, between the electronic control board and DDC (available as accessory). When such connection is made, the operation management and control of the unit takes place only through the DDC.

NOTE

The electronic control board is placed inside the electrical box of the unit and is visible from the front panel.

To interact with the regulating knob (*encoder*) of the electronic control board, it is necessary to remove the front panel of the unit and, without opening the electrical box, to act on the encoder by the supplied tube of about 4-3/4".

Operation Management And Control

The Display of the electronic control board, during the normal operation, shows in alternative mode the following information:

- Water inlet temperature (after the symbol t_i)
- Water outlet temperature (after the symbol t_o)
- Temperature difference ΔT (after the symbol t_d .)

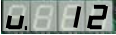
If anomalies are found, the electronic control board will show them on the display and will visualize the relative flashing unit codes. (i.e. ).

Until the unit code is not deactivated, display will show the unit code flashing. When there are more than one unit code deactivated, they will be visualized in alternative mode and flashing.

To enter the menu of electronic control board (visualization menu) press its ENCODER once: on the display the 1st menu entry will be visualized (menu 0, shown as .

NOTE

If any information (menu, menu entries, parameters and/or values, etc.) is visualized on the display in flashing mode, it means that this information couldn't be entered.

When an information is not available, the display visualizes: .



Rotating the encoder, all the other menu will be visualized on the display.

To exit and return to the precedent level, it is necessary to select the letter "E"

() by pressing the encoder.

To enter in menu and visualize menu entries it's necessary to stop on the desired menu and press the encoder: on the display the first menu entry of the same menu will be visualized .

NOTE

The menu entries will be identified on the display of the electronic control board through a number, where its maximum value is 3 digits (lined up at right). The visualization is characterized by the presence (on the 1st digit of display) of the menu identification number (example :  indicates entry 0, menu 0;  indicates menu entry 2, menu 0).

By **rotating the encoder**, all the other menu entries of the same menu will be visualized on the display.

To exit and return to the precedent level (default visualization), it is necessary to select the letter "E"

() by pressing the encoder.

MENU DESCRIPTION

The electronic control board presents nine menu (from 0 to 8), as follows:











| | |
|--|---|
| Menu 0: Data Visualization |  |
| Menu 1: Parameter Visualization |  |
| Menu 2: Actions |  |
| Menu 3: End User Adjustment |  |
| Menu 4: Adjustment by (Assistance Centers) |  |
| Menu 5: Adjustment (by Assistance Centers) |  |
| Menu 6: Unit Type Adjustment (by Assistance Centers) |  |
| Menu 7: Digital Inlet Visualization |  |
| Menu 8: Set Password (not manageable) |  |
| "E": Exit |  |

Table 26 – S61 MENUS

MENU 0, 1 and 7 are “Visualization Menu” (data and parameters are read-only). In menu 0 it’s possible to visualize the unit operation data detected from the electronic control board; In menu 1 it’s possible to real-time visualize the unit operation data and the unit management. In menu 7 a number will represent the state of digital Inlet.

MENU 2 is an “Execution Menu”; through this menu it’s possible execute actions like reset ignition control box and reset errors, as consequence of anomalies detected by the unit. The code will be visualized on the display of the electronic control board.

MENU 3, 4, 5 e 6 are “Adjustment Menu”, to adjust the contained information. Menu 3 is relative to the end-user, who can eventually (if allowed) modify the value of parameters; an example are cold water set point and the water temperature difference setup.

MENU 4, 5 e 6 are only to be managed by Robur Technical Assistance Authorized Centers.

NOTE

The electronic control board has three fuses for circuit protection. If the electronic control board does not start up or the condenser fan does not run, remove power from the unit and check the condition of the fuses. The S61 board requires a 10A (condenser fan) and two 2A fuses (electrical board). The size of the fuse is labeled on the electronic control board next to the respective fuse holder.

WARNING

The **maximum** current carrying capacity of the N.O. Contact is **4A**. Refer to Section 5.2, Pump Wiring.

WARNING

An isolation relay **MUST** be used to separate the UNIT transformer from additional equipment having a transformer or damage to the S61 board will occur. Refer to Section 5.3, Control Switch Wiring.

IGNITION CONTROL BOX

When power is supplied to the unit (to the “R” terminal on the ignition control box), ignition control will reset, perform a self check routine, flash the diagnostic LED, and enter thermostat scan state.

When the control switch is closed, the electronic control board will energize the ignition control box starting the ignition sequence (24 volts applied to the “W” terminal on the ignition box).

The ignition control box will check the differential air pressure switch for open contacts.

- If the differential air pressure switch contacts are closed and stay closed for 30 seconds, an air flow fault will be appear The diagnostic LED on the ignition control box indicates this fault. In this mode, the ignition control box pre-mixer blower will not start.

If the pressure switch contacts are open, the ignition control box pre-mixer blower will instead start.

- An air flow fault will occur if the air pressure switch contacts remain opened for 30 seconds after the pre-mixer blower start. The diagnostic LED on the ignition control box indicates this fault. In this mode, the ignition control box will keep the pre-mixer blower energized.

If the air pressure switch contacts close after the pre-mixer blower starts (normal operation), a pre-purge delay begins and the ignition sequence continues.

Next, the ignition control box energizes an ignition transformer that generates a high intensity spark at the igniter to ignite the gas/air mixture. Simultaneously, the gas valve is energized, allowing the flow of gas to the burner.

The ignition control box continuously monitors the flame sensor for ignition. If the flame sensor detects flame, the ignition transformer is de-energized immediately and the gas valve and pre-mixer blower remain energized.

Should the burner fail to light, or flame is not detected during the first trial for ignition, the gas valve and ignition transformer are de-energized and the ignition control box begins an inter-purge delay before another ignition attempt. The control will attempt two additional ignition trials (total of 3 ignition trials) before going into lockout. Upon lockout, the gas valve will de-energize immediately and the pre-mixer blower will turn off.

The thermostat ("W" terminal), air pressure switch and burner flame are constantly monitored to assure proper system operation. When the call for flame has ended (24volts removed from "W" terminal on ignition control), the gas valve is de-energized immediately. The ignition control then senses loss of flame and de-energizes the pre-mixer blower.

To reset the ignition box from menu2:

- To enter menu2, proceed as indicated above.
- In menu2, push the *encoder* on *menu signal 0* to enter the *reset ignition control box option*, visualized by the flashing code "reS0" (**F250**); push the *encoder* to confirm the reset operation.
- After confirmation, the display visualizes again the *menu signal* **2.880**.
- To exit, select the letter "E" (**E000**) and push the encoder.

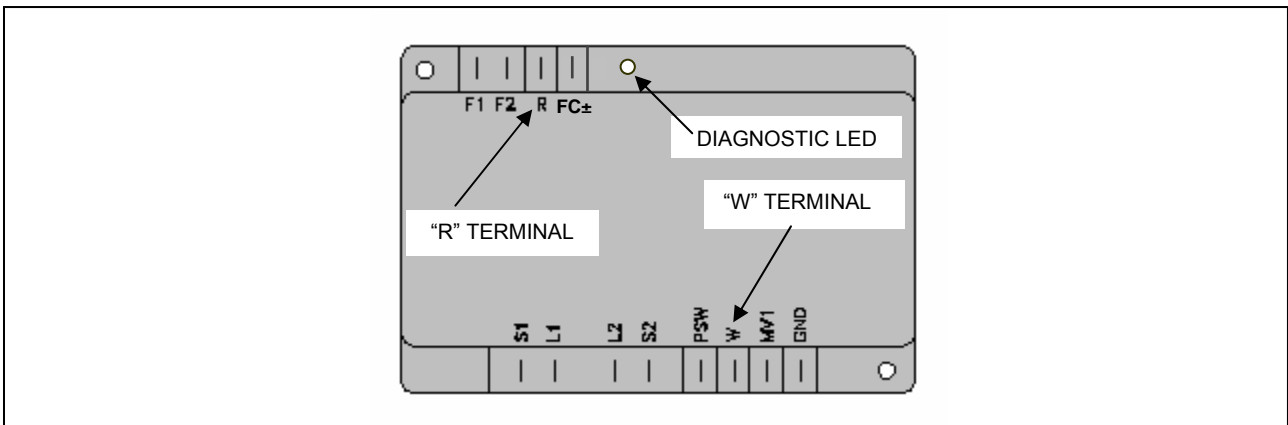

Figure 40 - IGNITION CONTROL BOX

TABLE OF OPERATING CODES GENERATED BY ELECTRONIC BOARD (firmware version 3.002)

| COLD MODULE | |
|--|--|
| U 1 | |
| GENERATOR THERMOSTAT LIMIT TEMPERATURE | |
| CODE GENERATED BY: | HIGH temperature detected by limit thermostat on body of generator. |
| RESET METHOD: | Reset limit thermostat manually: AYF operation will be restored automatically when the cause ceases. |
| E 1 | |
| GENERATOR THERMOSTAT LIMIT TEMPERATURE | |
| CODE GENERATED WHEN: | Code U 1 is active for 1 hour, or U 1 intervenes 3 times in 2 hours of operation. |
| RESET METHOD: | Contact ROBUR TAC. |
| U 2 | |
| EXHAUST FUMES THERMOSTAT | |
| CODE GENERATED BY: | HIGH temperature detected by exhaust fumes thermostat. |
| RESET METHOD: | Reset occurs automatically when the condition that generated the code ceases, with hysteresis of 14.4 °F (8 °C) |
| E 2 | |
| EXHAUST FUMES THERMOSTAT | |
| CODE GENERATED WHEN: | code U 2 is active for 1 hour, or generated 3 times in 2 hours of operation. |
| RESET METHOD: | Reset may be performed via DDC (or via S61 board via menu 2, menu item 1). If codes U 2 and/or E 2 occur again, contact ROBUR TAC. |
| U 3 | |
| COLD WATER ANTIFREEZE THERMOSTAT | |
| CODE GENERATED BY: | LOW temperature detected by cold outlet water sensor. |
| RESET METHOD: | Reset occurs automatically when the condition that generated the code ceases, with hysteresis of 3.6 °F (2 °C). |
| U 4 | |
| INADEQUATE VENTILATION / CONDENSER OVERHEATING | |
| CODE GENERATED BY: | (TCN - TA) values > limit set. |
| RESET METHOD: | Reset occurs automatically 20 minutes after the code is generated. |
| E 4 | |
| INADEQUATE VENTILATION / CONDENSER OVERHEATING | |
| CODE GENERATED WHEN: | Code U 4 is generated twice in 2 hours of operation. |
| RESET METHOD: | Carry out appropriate checks. Reset may be performed via DDC (or via S61 board, menu 2, menu item 1). If the code persists, contact ROBUR TAC. |
| E 5 | |
| HIGH AMBIENT TEMPERATURE | |
| CODE GENERATED BY: | HIGH temperature detected by ambient temperature sensor. |
| RESET METHOD: | Reset occurs automatically when the condition that generated the code ceases. |

| | |
|---|---|
| E 6 | |
| LOW AMBIENT TEMPERATURE | |
| CODE GENERATED BY: | LOW temperature detected by ambient temperature sensor. |
| RESET METHOD: | Reset occurs automatically when the condition that generated the code ceases. |
| u 7 | |
| HIGH CONDENSER INLET TEMPERATURE | |
| CODE GENERATED BY: | HIGH temperature detected by condenser inlet temperature sensor (T> limit set: menu 1, menu item 66) |
| RESET METHOD: | Reset occurs automatically when the condition that generated the code ceases. |
| E 7 | |
| HIGH CONDENSER INLET TEMPERATURE | |
| CODE GENERATED WHEN: | Code u 7 is active for 1 hour, or u 7 code is generated 12 times in 2 hours of operation. |
| RESET METHOD: | (with central flame control unit on) |
| E 8 | |
| FLAME CONTROL UNIT ERROR | |
| CODE GENERATED BY: | Code E12 on cold module and condenser inlet temperature increasing by over 18 °F (10 °C) within 1 hour. |
| RESET METHOD: | Carry out appropriate checks. Reset may be performed via DDC (or S61 board via menu 2, parameter 1). If the code persists, contact ROBUR TAC. |
| u 10 | |
| COLD WATER FLOW SWITCH: insufficient chilled water flow | |
| CODE GENERATED BY: | Insufficient cold water flow rate (circulator on and flow switch open). |
| RESET METHOD: | Reset occurs automatically when correct flow rate is restored. |
| E 10 | |
| COLD WATER FLOW SWITCH: insufficient chilled water flow | |
| CODE GENERATED WHEN: | Code u 10 is generated 5 times since appliance was powered, or code u 10 is active for one hour. |
| RESET METHOD: | Reset may be performed via DDC (or S61 board via menu 2, parameter 1). If the code persists, contact ROBUR TAC. |
| u 11 | |
| INSUFFICIENT ROTATION OF OIL HYDRAULIC PUMP | |
| CODE GENERATED BY: | Insufficient rotation of oil hydraulic pump. |
| RESET METHOD: | Reset occurs automatically 20 minutes after the code is generated. |
| E 11 | |
| INSUFFICIENT ROTATION OF OIL HYDRAULIC PUMP | |
| CODE GENERATED WHEN: | code u 11 is generated twice in 2 hours of operation. |
| RESET METHOD: | Reset may be performed via DDC (or S61 board via menu 2, parameter 1). If the code persists, contact ROBUR TAC. |
| u 12 | |
| FLAME CONTROL UNIT ARREST | |
| CODE GENERATED BY: | Failure of burner to ignite. |
| RESET METHOD: | Reset occurs automatically when the electrovalve opens again (new attempt at ignition) or after code is active for 5 minutes. |

| | |
|--|--|
| E 12 | |
| FLAME CONTROL UNIT ARREST | |
| CODE GENERATED BY: | Flame arrest signal. |
| RESET METHOD: | Reset may be performed via DDC (or S61 board via menu 2, parameter 0). If the code persists, contact ROBUR TAC. |
| E 16 | |
| OUTLET WATER TEMPERATURE SENSOR DEFECTIVE | |
| CODE GENERATED BY: | Fault (interruption or short circuit) on outlet water temperature sensor. |
| RESET METHOD: | Reset may be performed via DDC (or S61 board via menu 2, parameter 1). If the code persists, contact ROBUR TAC. |
| E 17 | |
| COLD INLET WATER TEMPERATURE SENSOR DEFECTIVE | |
| CODE GENERATED BY: | Fault (interruption or short circuit) on condenser inlet water temperature sensor. |
| RESET METHOD: | Reset may be performed via DDC (or S61 board via menu 2, parameter 1). If the code persists, contact ROBUR TAC. |
| E 18 | |
| CONDENSER OUTLET TEMPERATURE SENSOR DEFECTIVE | |
| CODE GENERATED BY: | Fault (interruption or short circuit) on condenser outlet temperature sensor. |
| RESET METHOD: | Reset may be performed via DDC (or S61 board via menu 2, parameter 1). If the code persists, contact ROBUR TAC. |
| E 20 | |
| CONDENSER INLET TEMPERATURE SENSOR DEFECTIVE | |
| CODE GENERATED BY: | Fault (interruption or short circuit) on condenser inlet temperature sensor. |
| RESET METHOD: | Reset may be performed via DDC (or S61 board via menu 2, parameter 1). If the code persists, contact ROBUR TAC. |
| u 29 | |
| GAS ELECTROVALVE WITHOUT ELECTRICAL POWER | |
| CODE GENERATED WHEN: | Gas electrovalve is off for 5 seconds (with central flame control unit on). |
| RESET METHOD: | Reset occurs automatically if the gas electrovalve switches on again within 10 minutes (with central flame control unit on). |
| E 29 | |
| GAS ELECTROVALVE WITHOUT ELECTRICAL POWER | |
| CODE GENERATED WHEN: | Code u 29 is active for more than 10 minutes (with central flame control unit on). |
| RESET METHOD: | Carry out appropriate checks. Reset may be performed via DDC (or S61 board via menu 2, parameter 1). If the code persists, contact ROBUR TAC. |
| u 51 | |
| ANTIFREEZE FUNCTION ACTIVATED – COOLING MODULE | |
| Activation takes place only if the cold module is off and the antifreeze function is enabled (see menu 1, parameter 77). | |
| CODE GENERATED WHEN: | Inlet or outlet water temperature of the cold module falls below 39.2 °F (4 °C - the code generated signals that the antifreeze function has been activated). In this case the antifreeze function activates the plant water circulator. |
| RESET METHOD: | Reset (deactivation of antifreeze function) occurs automatically when, with only the circulator on, the inlet and outlet water temperatures return to over 41 °F (5 °C - in this case the circulator switches off), or if the function itself is disabled. |

| | |
|---|--|
| u 77 | |
| COLD MODULE FLOW SWITCH "ON" | |
| CODE GENERATED BY: | The flow switch of the cold module detects that water is present in the plant , when (and only in this situation) the appliance is configured as a 2-pipe cold-hot plant and the plant is operating in hot mode at that moment. |
| RESET METHOD: | Reset occurs automatically when the condition that generated the code ceases. |
| ELECTRONIC BOARD | |
| u 80 | |
| INCOMPLETE PARAMETERS | |
| CODE GENERATED BY: | Incomplete parameters. |
| RESET METHOD: | The code remains active until operating parameters have been entered and completed. Contact ROBUR TAC. |
| NB: If the board is replaced, code E80 may appear: this means that AY/AYF characterisation data has not been entered. | |
| E 80 | |
| INVALID PARAMETERS | |
| CODE GENERATED BY: | Invalid parameters or damage to parameter memory. |
| RESET METHOD: | Reset is automatic when the correct parameters are entered. If the code persists, contact the ROBUR TAC: if the parameters are incorrect, it is necessary to enter and complete the operating and characterisation parameters; if the memory is damaged it is necessary to replace the board. |
| u 81 - u 82 | |
| INVALID BANK 1 DATA - INVALID BANK 2 DATA | |
| CODE GENERATED BY: | Invalid Bank 1 data - Invalid Bank 2 data. |
| RESET METHOD: | Reset occurs automatically 5 seconds after the code is generated. |
| E 81 - E 82 | |
| INVALID BANK 1 DATA - INVALID BANK 2 DATA | |
| CODE GENERATED BY: | Invalid Bank 1 data - Invalid Bank 2 data. |
| RESET METHOD: | Reset may be performed via the S61/AY10 board via menu 2, parameter 1 or 21. If the code persists, contact ROBUR TAC. |
| E 84 | |
| FAULTY CONNECTIONS OF 24 Vac TRANSFORMER OR FUSES | |
| CODE GENERATED BY: | Damage to 1 of the 2 24-0-24 Vac input fuses or one of 24-0-24 Vac wires to the board not supplying current. |
| RESET METHOD: | Check 24-0-24 Vac fuses and electrical power connections on the board. Reset may be carried out via DDC (or via S61 board via menu 2, menu item 1). If the code persists or occurs again, contact ROBUR TAC. |
| E 85 | |
| INCORRECT MODULE TYPES (from menu 6) | |
| CODE GENERATED WHEN: | The module type set (from menu 6) does not correspond to the one managed by the board. |
| RESET METHOD: | Reset occurs automatically when the correct parameters are entered. If the code persists, contact ROBUR TAC. |
| E 86 - E 87 - E 88 - E 89 | |
| MEMORY TEST UNSUCCESSFUL | |
| CODE GENERATED BY: | Processor error. |
| RESET METHOD: | Contact ROBUR TAC. |

| | |
|--------------------------------------|--|
| E 90 | |
| AMBIENT TEMPERATURE SENSOR DEFECTIVE | |
| CODE GENERATED BY: | Interruption or short circuit of ambient temperature sensor. |
| RESET METHOD: | Reset may be performed via DDC (or S61 board via menu 2, menu item 1). If the code persists, contact ROBUR TAC. |
| E 91 | |
| BOARD DEFECTIVE | |
| CODE GENERATED WHEN: | One of the following is absent: serial number of board, hardware version code or encryption key written during board test. |
| RESET METHOD: | Contact ROBUR TAC. |

Table 27 - Operating codes generated by S61/AY10 electronic board
(codes may also be visualised by DDC display).

IN TABLE, TAC = AUTHORISED ROBUR TECHNICAL ASSISTANCE CENTRE

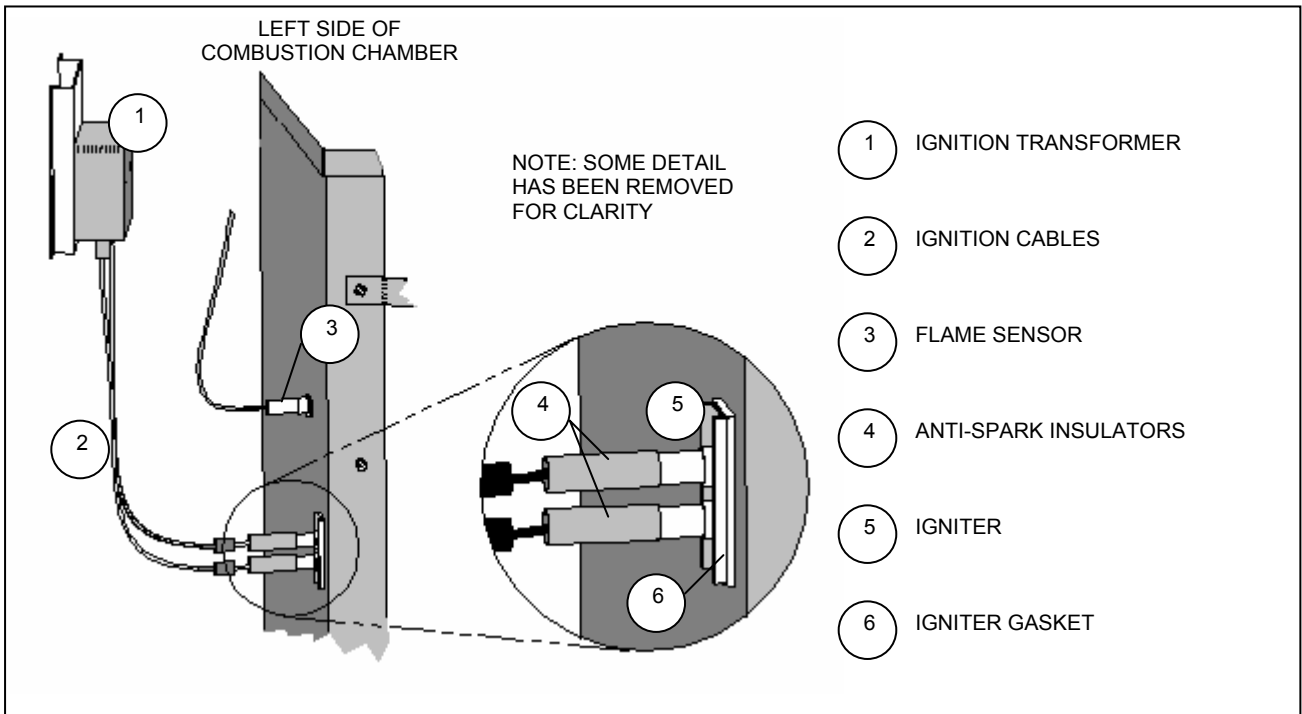

Figure 41 – IGNITION TRANSFORMER, IGNITER ASSEMBLY, AND FLAME SENSOR

Robur is dedicated to dynamic progression
in research, development and promotion
of safe, environmentally-friendly, energy-efficiency products,
through the commitment and caring
of its employees and partners

Robur Mission



Robur Corporation
advanced heating
and cooling technologies
827 E. Franklin Street
Evansville, Indiana 47711 USA
P (812) 424 1800 F (812) 422 5117
www.robur.com/us
rhalbig.serve@sbcglobal.net